



[www.urma.ch](http://www.urma.ch)



**Change Your Mind**  
Think small

SWISS  QUALITY

**URMA** CircoTec RX small

BRAND-NEW



BRAND-NEW

## Markkinoiden pienin modulaarinen kalvain jossa vaihdettavat teräpalat\*

Worldwide Smallest Modular  
Replaceable Insert Reaming  
System\*

\* patenttia haettu  
patent pending

Ø 7.600 - 13.100 mm

BRAND-NEW

### Etuja käytettäessä CircoTec RX small kalvimia

Advantages of Using CircoTec RX small

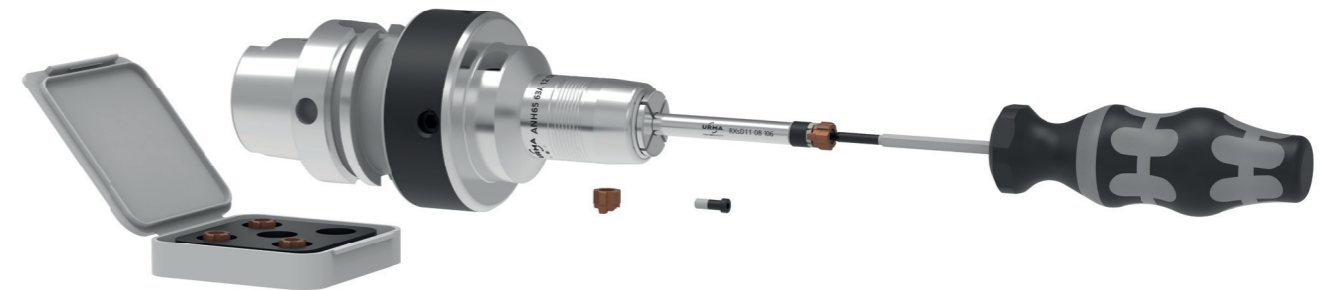

#### Vaihdeettava teräpala kalvin

Maailmanlaajuisesti pienin modulaarinen vaihtopalkalvin kokoluokkaan 7.600 mm - 13.100 mm

#### Helppo käyttöinen

Helppo ja nopea teräpalkanvaihto

#### Tarkka paikoitus

Erittäin tarkka teräpalkan uudelleen paikoittuminen

#### Laaja standardikokojen tuotanto

Erikoiskoot ilman lisähintaa

#### Laaja käytettävyys

Työstömateriaalit, erikoiset teräpalat ja varret mahdollistavat laajan käytettävyyden

#### Kustannustehokkuus per tuote

Alhainen työkalukustannus, tuotannon tehostuminen ja pitkäikäisyys vähentävät logistisia kuluja

#### Replaceable Insert Reaming System

Worldwide smallest modular reaming tool with diameter from 7.600 mm to 13.100 mm

#### Simple Handling

Fast and simple insert change

#### Highest Precision in Positioning Accuracy

Highest repeatability on each insert change

#### Largest Standard Product Line

Customer-specific diameter without any surcharge

#### High Flexibility

Cutting materials, insert and shank system provide a high level of flexibility

#### Low Costs per Part

A replaceable insert reaming system allows for low tool costs, increased productivity and the elimination of logistics costs

Ø 7.600 - 13.100 mm

BRAND-NEW

## Teräpala

Inserts

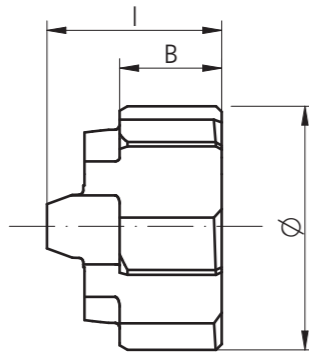

### Suorahampainen

Straight Fluted Inserts

RX small System Size	Ø - Range mm	B	l	z	MB	VE	Order Number	Index
RXs 08	7.600 - 8.100	4.5	7.1	4	3	5	RXsG...	○
RXs 10	8.101 - 9.600	4.5	7.5	6	3	5	Order example	○
RXs 11	9.601 - 11.100	4.5	7.7	6	3	5	page 13	○
RXs 13	11.101 - 13.100	4.5	7.7	6	3	5		○

### Nousullinen teräpala, vasen

Left Helical Fluted Inserts

RX small System Size	Ø - Range mm	B	l	z	MB	VE	Order Number	Index
RXs 08	7.600 - 8.100	4.5	7.1	4	3	5	RXsL...	○
RXs 10	8.101 - 9.600	4.5	7.5	6	3	5	Order example	○
RXs 11	9.601 - 11.100	4.5	7.7	6	3	5	page 13	○
RXs 13	11.101 - 13.100	4.5	7.7	6	3	5		○

**B** Leikkuupitus  
**l** Kokonaispituus  
**z** Hammasluku  
**MB** Minimi tilausmäärä  
**VE** Pakkauskoko

**B** Length (flutes)  
**l** Total length  
**z** Number of teeth  
**MB** Minimum order  
**VE** Packaging quantity

Index ● Varastossa  
Stock standard

○ Lyhyellä toimitusajalla  
Short-term availability from semi-finished product stock

Ø 7.600 - 13.100 mm

BRAND-NEW

## Teräpitimet

Insert Holders

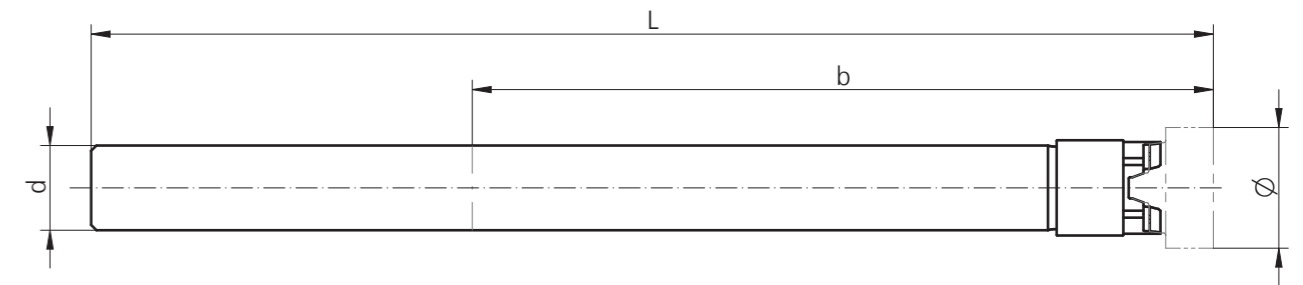

### Lyhytmalli (Teräs)

Short Version (Steel)



RX small System Size	Ø - Range mm	L	b	d / h6	Order Number «D»	Order Number «B»	Index
RXs 08	7.600 - 8.100	86	50	6	RXsD08 06 086*	RXsB08 06 086*	●
RXs 10	8.101 - 9.600	96	60	6	RXsD10 06 096*	RXsB10 06 096*	●
RXs 11	9.601 - 11.100	106	70	8	RXsD11 08 106*	RXsB11 08 106*	●
RXs 13	11.101 - 13.100	120	84	8	RXsD13 08 120*	RXsB13 08 120*	●

### Pitkämalli (kovametalli)

Long Version (Carbide)



RX small System Size	Ø - Range mm	L	b	d / h6	Order Number «D»	Order Number «B»	Index
RXs 08	7.600 - 8.100	102	66	6	RXsD08 06 102HM*	RXsB08 06 102HM*	●
RXs 10	8.101 - 9.600	116	80	6	RXsD10 06 116HM*	RXsB10 06 116HM*	●
RXs 11	9.601 - 11.100	126	90	8	RXsD11 08 126HM*	RXsB11 08 126HM*	●
RXs 13	11.101 - 13.100	150	114	8	RXsD13 08 150HM*	RXsB13 08 150HM*	●

**L** Kokonaispituus  
**b** Käyttöpituus  
**d** Halkaisija  
**D** Läpäreikä  
**B** Pohjäreikä

**L** Total length  
**b** Effective length  
**d** Diameter  
**D** Through bore  
**B** Blind hole

\* Lyhyempiä saatavana tilauksesta (Lisäkulu)  
can be shortened to the optimal length upon request

### SPARE PARTS

RX small System Size	Spare Parts «D»	Spare Parts «B»
RXs 08	C00 90 51	C00 90 51
RXs 10	C00 90 52	C00 90 52
RXs 11	C00 90 53	C00 90 53B
RXs 13	C00 90 54	C00 90 54B

## Kartiot

## Accessories



## Hydrauli-istukka kompensoinnilla

Hydraulic Compensating Chuck

## DIN 69871 AD/B

	D	d	L	SW <sub>1</sub>	SW <sub>2</sub>	Order Number	Index
40	76	12	135	5	4	AND65 40A 12 135	●
50	76	12	160	5	4	AND65 50A 12 160	●

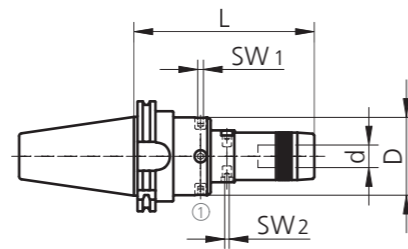

## MAS-BT-A

	D	d	L	SW <sub>1</sub>	SW <sub>2</sub>	Order Number	Index
40	76	12	135	5	4	ANT65 40A 12 135	●
50	76	12	135	5	4	ANT65 50A 12 135	●

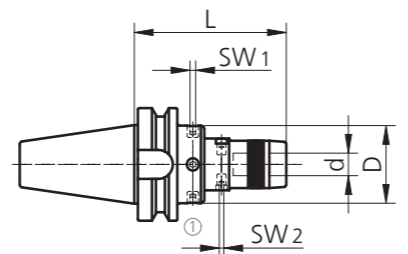

## DIN 69893-HSK-A

	D	d	L	SW <sub>1</sub>	SW <sub>2</sub>	Order Number	Index
63	76	12	135	5	4	ANH65 63A 12 135	●

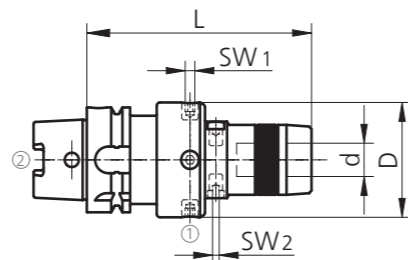

## Holkki hydrauli-istukkaan

Reducers for Hydraulic Compensating Chuck

D1	D2	D3	L1	L2	Order Number	Index
12	6	26	49	4	67 12 06	●
12	8	26	49	4	67 12 08	●

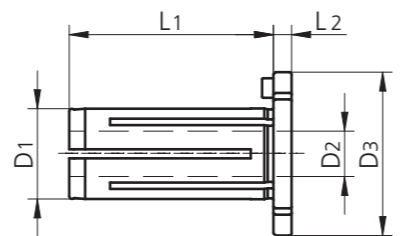

## SPARE PARTS

d	Order Number	Index
12	C00 03 44	●
20	C00 03 44	●
32	C00 03 45	●



## COOLANT TUBE

	Order Number	Index
63	H00 63 01	●
100	H00 100 01	●

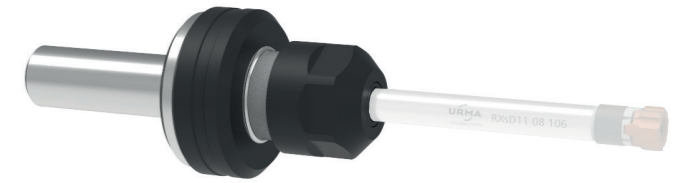
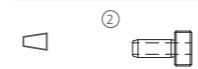

## Uivaistukka

Floating Chuck

## Cylindrical Shaft DIN 1835-A

Adaptors	Size	Range	D	d <sub>1</sub>	d <sub>2</sub>	L	Oscillation	Order Number	Index
ZS 16	ER16	1.0 - 10.0	16	28	42	44	±1	PZ60 16 16 044	○
ZS 20	ER16	1.0 - 10.0	20	28	42	44	±1	PZ60 16 20 044	●

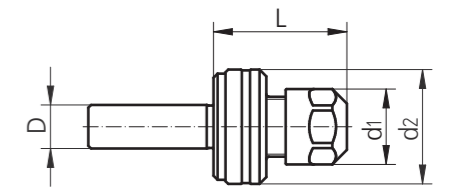

Sisältää mutterin jossa paikka tiivisterenkaalle  
Scope of delivery: collet nut for seal disk included

ZS Sylinterimalli  
Cylindrical shank

## Mutteri tiivisterenkaalle

Collet Nut for Seal Disk

Size	D	Thread	Order Number	Index
ER16 P	28	M22 x 1.5	20.107.210	●

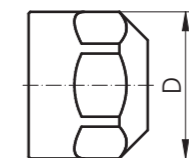

## Mutterin avain

Spanner

Size	Order Number	Index
ER16	53 00 22	●



## Sisältyy toimitukseen

Included in delivery

## Holkit

Collets

Size	D	d	L	Order Number	Index
ER16	17	3.0 - 10.0	27.5	62 16 XX	●

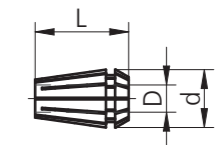

XX = ø d Example: d = 10 = 62 16 10

## Tiivisterengas mutterille

Seal Disk for Collet Nut

Size	D	Order Number	Index
ER16	3.0 - 10.0	20.107.21 XXX	●

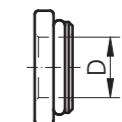

XXX = d Example: d = 9.0 = 20.107.21 090



#### Asetusrengas kellotusta varten

Run-Out Indicating Insert

RX small System Size	Order Number	Index
RXs 08	RXsC08 06 02	●
RXs 10	RXsC10 06 02	●
RXs 11	RXsC11 06 03	●
RXs 13	RXsC13 06 03	●

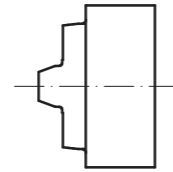

#### Torx momenttiavain

Torx-Torque Wrench

RX small System Size	Clamping Torque	Torque Size	Order Number	Index
RXs 08	0.6 Nm	T6	G00 40 15	●
RXs 10	0.9 Nm	T7	G00 40 14	●
RXs 11	1.4 Nm	T9	G00 40 16	●
RXs 13	2.0 Nm	T10	G00 40 17	●



Index

● Varastossa  
Stock standard○ Lyhyellä toimitusajalla  
Short-term availability

Ø 7.600 - 13.100 mm

#### Käyttöalue CircoTec RX small

Scope of CircoTec RX small Application

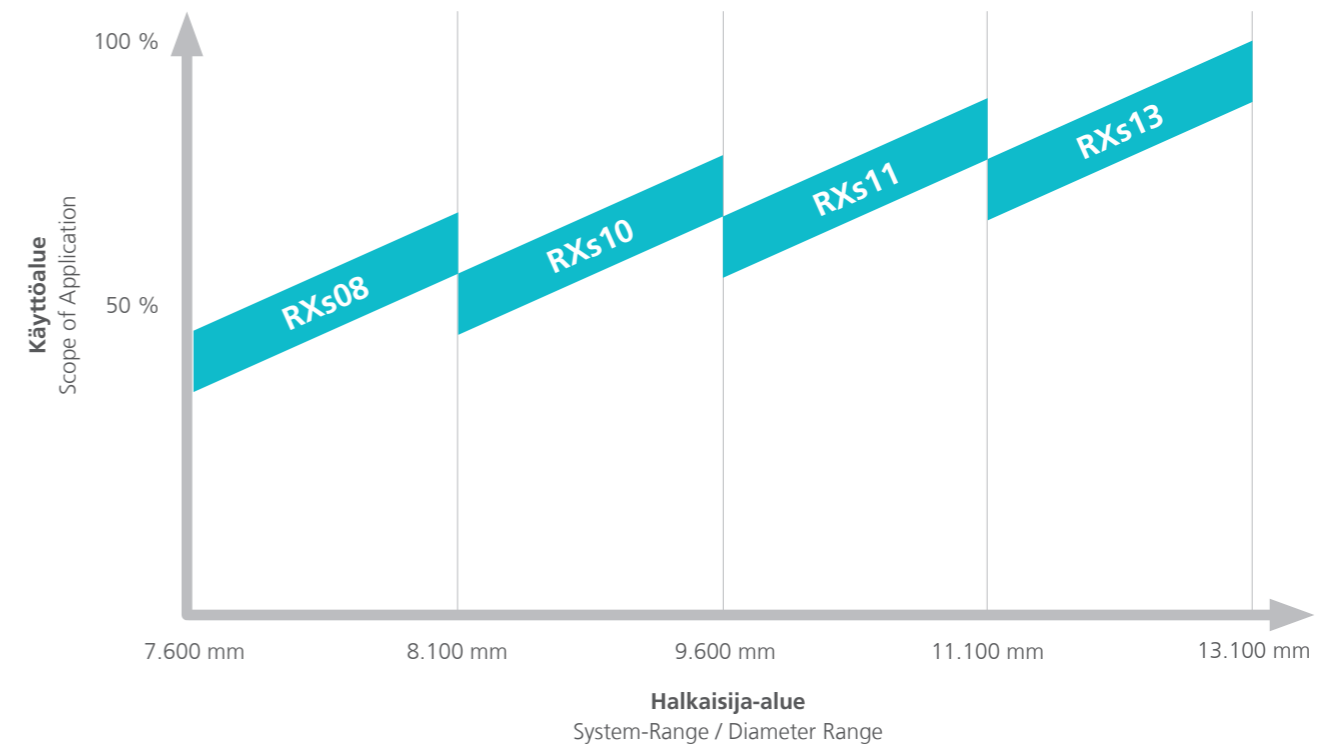

#### Käyttöalue riippuu:

- **Materiaali**  
Koneistettavuudesta ja vetolujuudesta
- **Kokoluokka**  
Teräkseen kasvaessa myös väännön tarve kasvaa
- **Esiporaus**  
Mitä suurempi poraus on (saatavuuden rajoissa) sitä enemmän lastutilaa
- **Jäähdytys**  
Jäähdytystapa ja paine
- **Lastunpaksuus (ap)**  
koko ja esikoneistuksen tarkkuus

#### The scope of application is dependent on:

- **Material**  
Tensile strength and machinability
- **System Size**  
The bigger the system size, the better the torque transmission
- **Bore Diameter**  
The larger the diameter (within the system size), the more space for chips
- **Coolant**  
Supply and pressure
- **Stock Removal (ap)**  
Size and monitoring of pre-machining

BRAND-NEW

## Tietoa Terän halkaisijasta

### Explanation of Insert Size

Huomioitavaa tilauksien yhteydessä reijän toleranssista. Halkaisija määritetään URMA standardin mukaisesti. Riippuen reiän toleranssi alueesta. Lopullinen halkaisija liikkuu 65% - 80% tietämällä kokonaistoleranssista.

#### Esimerkki vakioteräpalasta

RXsG8H7-A01 F0512R1

Teräpala hiotaan mittaan **Ø 8.011 mm**

RXsG8+20-10-A01 F0512R1

Teräpala hiotaan mittaan **Ø 8.015 mm**

Q merkitty teräpala kertoo, että kyseessä on erityinen toleranssi johon on tarpeen tehdä tarkemmalla hionnalla oleva teräpala.

#### Esimerkki Q teräpalasta

RXsG8.020Q+3-3-A01 F0512R1

Teräpala hiotaan mittaan **Ø 8.020 mm**

For orders with specifications of bore tolerance, the diameter is defined by URMA standard. Depending on tolerance range, the final diameter will be within 65% to 80% of the total tolerance.

#### Examples Standard Insert Designation

RXsG8H7-A01 F0512R1

insert ground to **Ø 8.011 mm**

RXsG8+20-10-A01 F0512R1

insert ground to **Ø 8.015 mm**

A Q-insert designation is to be selected for any specific insert dimension. Opposed to standard inserts where all tolerances refer to the bore tolerance, Q-inserts indicate the required insert diameter (target size).

Q-inserts are recommended for special applications where standard tolerance ranges are not applicable.

#### Example Q-Insert Designation

RXsG8.020Q+3-3-A01 F0512R1

insert ground to **Ø 8.020 mm**

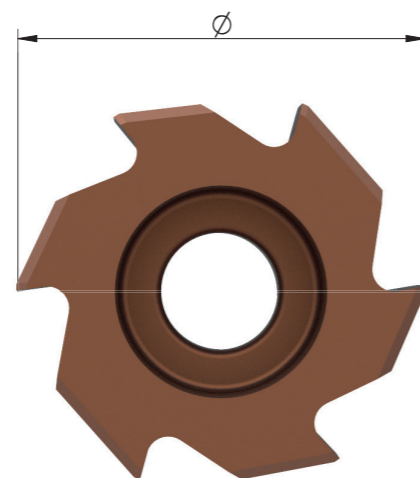

## Tilausesimerkkejä

### Order Example

#### Tilausesimerkki ISO toleranssi

Order Example in Accordance with ISO Tolerances

#### Tilausnumero:

Order Number:

RXsG8.3H7-A01M2 F0512R1

**RXs**

**RX small tuotemerkintä**  
RX small system designation

**G**

**Hammasmuoto (G = Suora; L = nousullinen)**  
Flute form (G = straight; L = left-hand helix)

**8.3**

**Halkaisija mm**  
Diameter in mm

**H7**

**Toleranssi ISO vakio µm +/-**  
Tolerance in ISO standard or µm +/-

**A01**

**Leikkuugeometria**  
Cutting geometry

**M2**

**Nano viimeistely**  
Nano finishing (edge preparation)

**F05**

**Materiaali**  
Cutting material

**12R**

**Pinnoite**  
Coating

**1**

**1 = ohut pinnoite; 2 = Paksu pinnoite**  
1 = thin coating; 2 = thick coating

#### Tilausesimerkki special teräpalasta (Q teräpala)

Order Example with Target Size (Q-Insert)

#### Tilausnumero:

Order Number:

RXsG8.304Q+3-3-A01M2 F0512R1

**RXs**

**RX small Tuotemerkintä**  
RX small system designation

**G**

**Hammasmuoto (G = Suora; L = Nousullinen)**  
Flute form (G = straight; L = left-hand helix)

**8.304**

**Tarkkuushionnan halkaisija mm**  
Target size/diameter in mm

**Q**

**Tarkkuushiotun teräpalan koodi**  
Code for target size insert

**+3-3**

**Valmistustoleranssi +/-**  
Manufacturing tolerance +/-

**A01**

**Leikkuugeometria**  
Cutting geometry

**M2**

**Nano viimeistely**  
Nano finishing (edge preparation)

**F05**

**Materiaali**  
Cutting material

**12R**

**Pinnoite**  
Coating

**1**

**1 = Ohut pinnoite; 2 = Paksu pinnoite**  
1 = thin coating; 2 = thick coating

Ø 7.600 - 13.100 mm

## Käyttöohjeita RX smal

### Handling Instructions RX small

#### Teräpalan vaihtaminen

##### Insert Change

Optimaalisen tarkkuuden saavuttamiseksi tulee kiinnittää huomiota teräpesän puhtauteen ja teräpalan oikeaan kiinnitysovoimaan..

For optimal performance, proper cleaning of the interface as well as using the pre-defined tightening torque are imperative.

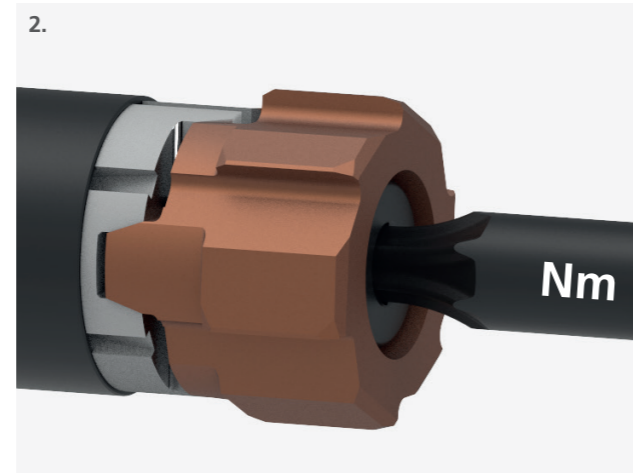
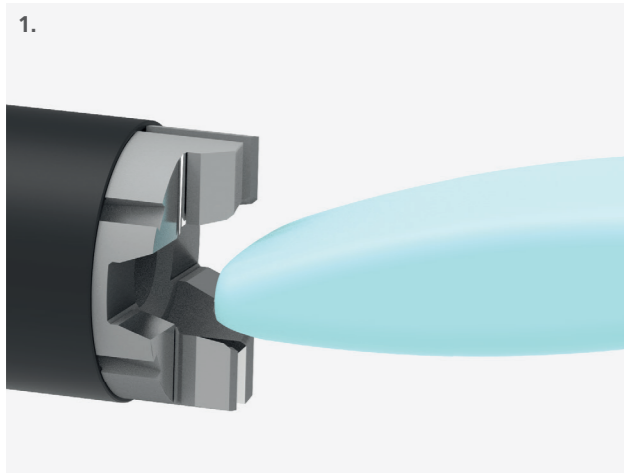

#### 1. Puhdistus

Parastapa viimeistellä puhdistus on mukana tuleva sinitarra.

#### 2. Teräpalan vaihtaminen

Puhdista myös teräpalan kontaktipinnat huolellisesti ja käytä oikeita kiinnitysoimia kiristäessäsi teräpalaa.

#### 1. Cleaning of the Interface

The interface can be cleaned most effectively with the modeling clay enclosed in the insert packaging.

#### 2. Insert Change

The insert is placed on the previously cleaned interface and tightened through the predetermined tightening torque.

#### Torx momenttiavain

##### Torx-Torque Wrench

RX small System Size	Clamping Torque	Torque Size	Order Number
RXs 08	0.6 Nm	T6	G00 40 15
RXs 10	0.9 Nm	T7	G00 40 14
RXs 11	1.4 Nm	T9	G00 40 16
RXs 13	2.0 Nm	T10	G00 40 17

Ø 7.600 - 13.100 mm

## Käyttöohjeita RX small

### Handling Instructions RX small

#### Heiton säätö

##### Run-Out Adjustment

Parhaimman tuloksen saavuttamiseksi tulee kalvain aina kellottaa heitottomaksi. Tällä tavalla pystytään eliminoimaan kaikki virheet jotka voivat johtua työkalukokoonpanosta tai työstökoneen karasta. Työkalu tulee aina kiinnittää joko säädettävään tai uivaan -istukkaan. Heitottomuus voidaan mitata eri menetelmin.

In order to achieve the best reaming results possible, a tool with zero run-out is desirable. So as to compensate for any errors due to run-out from the tool holders or the machine spindle, we recommend using a compensation holder or floating chuck. The run-out of CircoTec RX small reamers can be measured with different methods:

#### 3. Erityisellä lieriömallisella teräpalalla

Helpointa on hyödyntää erityistä lieriömallista teräpalaa kellotuksen apuna.

#### 4. Teräpalan ulkopinnasta

CircoTec RX small työkalut on valmistettu erittäin tarkkoilla toleransseilla ja säätäminen onnistuu myös teräpalan ulkopinnasta. Mutta tämä tapa on huomattavasti työläämpi ja siksi suositellaan käytettäväksi kellotusrengasta.

#### 3. Measurement Through Run-Out Indicating Insert

The run-out can be easily set up and precisely checked by means of an indicating insert.

#### 4. Measurement on the External Diameter of the Insert

The CircoTec RX small inserts can also be set up via on the small margin. Its handling is, however, more difficult.

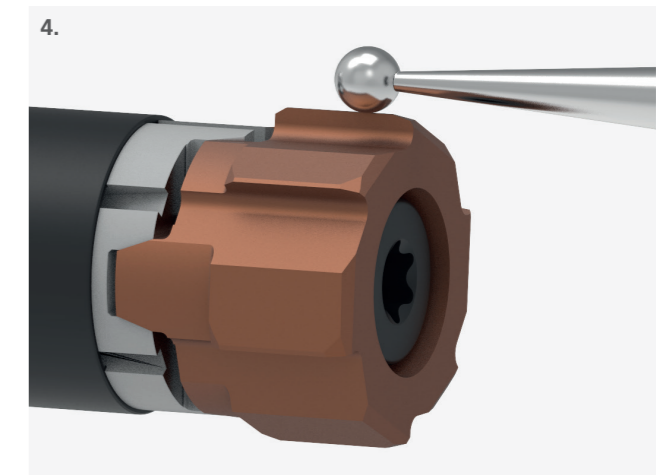
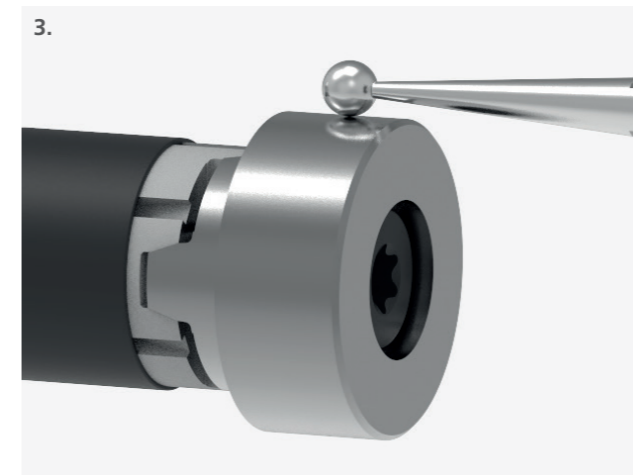





Ø 7.600 - 13.100 mm	CircoTec RX small
Ø 11.900 - 140.600 mm	CircoTec RX

### URMA CircoTec RX kalvimien edut

#### URMA CircoTec RX Reamer Portfolio

##### CircoTec RX etuja

- Edullinen kustannus per tuote
- Laaja valikoima laatuja ja geometrioita
- Vähäinen säätötarve

##### Prosessin luotettavuus

- Tarkkuus
- Pitkä kestoikä

##### Teräpalanvaihto

- Helppokäyttöisyys
- Suuri paikoitustarkkuus

##### CircoTec RX Facts

- Lower costs per part
- Wide variety of grades and geometries
- Low adjustment efforts

##### Process Reliability

- Constant precision
- Long tool life

##### Changing Reaming Inserts

- Easy handling
- Maximum positioning accuracy

# URMA Tools

## Reaming & Boring





#### **URMA AG WERKZEUGFABRIK**

Obermatt 3  
CH-5102 Ruppertswil  
Switzerland  
T +41 62 889 20 20  
F +41 62 889 20 28  
info@urma.ch  
www.urma.ch

#### **Subsidiaries**

URMA GmbH  
Eisenbahnstraße 37  
D-77815 Bühl  
+49 7223 911 170  
info@urma-gmbh.de

URMA Trading (Shanghai) Co. Ltd.  
Room 511, Hua Nan Mansion  
1988 Dongfang Road  
Pudong New District  
CN-200125 Shanghai  
+86 (21) 6109 6216  
info@urmachina.com

Iraupen URMA  
Poligono Belartza  
ES-20018 Donostia-San Sebastian  
Spain  
+34 943 667 036  
info@iraupen.es

#### **License Manufacturer**

Command Tooling Systems, LLC  
13931 Sunfish Lake Blvd.  
Ramsey MN, 55303 USA  
+1 800 328 2197  
support@commandtool.com

Paul Horn GmbH  
Unter dem Holz 33-35  
D-72072 Tübingen  
+49 (0) 7071 7004 0  
info@phorn.de

Sumitomo Electric Ind., Ltd.  
1-1-1, Koyakita,  
Itami-shi, Hyogo 664-0016  
Japan  
+81 72 772 4535  
info@sumitomotool.com