



www.urma.ch

A close-up photograph of a precision tool, likely a dial indicator or a similar measuring instrument. The tool has a metallic, polished surface. A circular gauge with a scale and a needle is visible. In the foreground, there is a small, dark, circular component with several gold-colored pads or contacts on its surface. The background is a soft, out-of-focus light gray.

**Innovation is
our Tool**

SWISS  QUALITY

URMA Systems

URMA Tools

Reaming & Boring



| | |
|------------------|----------------------|
| Ø 0.2 - 2'400 mm | |
| Ø 0.2 - 40 mm | FINISHING |
| Ø 19.5 - 153 mm | ROUGHING |
| Ø 18 - 153 mm | FINISHING |
| Ø 49 - 297 mm | ROUGHING + FINISHING |
| Ø 150 - 805 mm | ROUGHING + FINISHING |
| Ø 500 - 2'400 mm | ROUGHING + FINISHING |
| Ø 20 - 51 mm | |













Index

● Lagerstandard
Stock standard

○ Index B, Verfügbarkeit auf Anfrage
Index B, availability on request

Inhaltsverzeichnis

Table of contents

| | | | |
|-------------------------------|-------------------------------|---|-----|
| Alpha-/Beta-Modul System | Alpha-/Beta-Modul System |  | 7 |
| DigiTec | DigiTec |  | 11 |
| MicroMax | MicroMax |  | 19 |
| VersaMax - Type 14 | VersaMax - Type 14 |  | 29 |
| VersaMax - Type 25 / Type A25 | VersaMax - Type 25 / Type A25 |  | 39 |
| IntraMax | IntraMax |  | 51 |
| MegaMax | MegaMax |  | 69 |
| SuperMegaMax | SuperMegaMax |  | 81 |
| LBS-System | LBS-System |  | 89 |
| Modulare Komponente | Modular components |  | 97 |
| Adapter Werkzeuge | Adaptor toolholders |  | 115 |
| Sonderwerkzeuge | Special tools |  | 121 |
| Bearbeitungsstudie | Machining study | | 125 |
| Bedienungsanleitungen | Manuals | | 129 |
| WinTool | WinTool | | 137 |

URMA Systems
Alpha-/Beta-Modul System

Ø 0.2 - 2'400 mm

Alpha-Modul-System



Axiale Schraubverbindung

- hohe Stabilität
- Massensymmetrie erlaubt hohe Drehzahlen
- einfache Handhabung
- Adapter zu Beta-Modul

Axial Threaded Connection

- high stability
- mass symmetry allows high revolutions per minute
- simpler handling
- adaptor for Beta-Modul

Ø 0.2 - 2'400 mm

Beta-Modul-System



Radial Spannung

- hohe Flexibilität
- kompatibel zu anderen Systemen
- höhere Übertragungsmomente durch grössere Kegelflächen und Mitnahmekeil
- einfache Handhabung
- Adapter zu Alpha-Modul

With Side Lock System

- high flexibility
- compatible to other systems
- large surface area of conical drive key allows for higher torque transmission
- simpler handling
- adaptor for Alpha-Modul

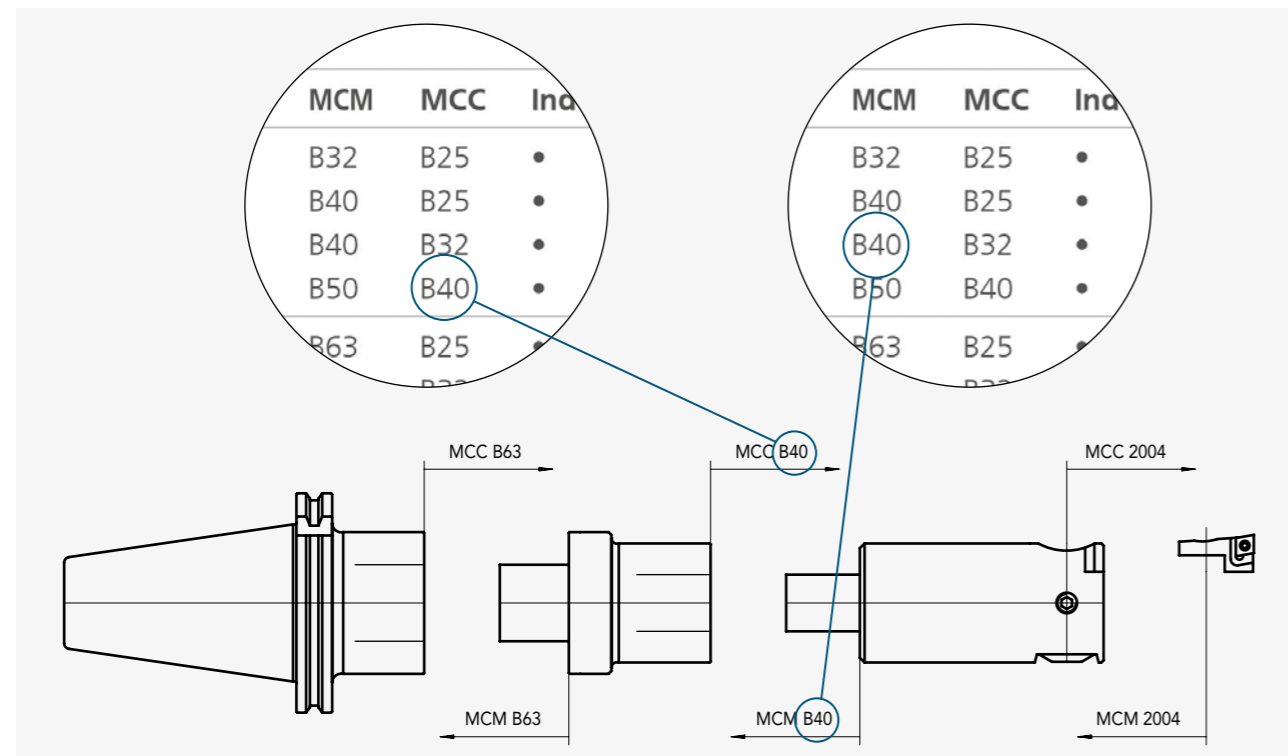

Handhabung der URMA Fügebedingungen

- MCC Fügebedingung Richtung Schneide
- MCM Fügebedingung Richtung Maschine

MCC und MCM zeigen die verschiedenen Verbindungsmerkmale für den Zusammenbau von Werkzeugkomponenten. Diese Fügebedingungen müssen gegenseitig übereinstimmen (Beispiel Seite 8).

Handling of URMA Match Codes

- MCC Match Code towards Cutting Edges
- MCM Match Code towards Machine

MCC and MCM show the different couplings to mount the tool components. These match codes have to correspond (example page 8).

URMA Systems
DigiTec

Ø 0.2 - 2'400 mm

DigiTec

Das digitale Feinbohrsystem zum unschlagbaren Preis!

The digital fine boring system at a fair price!



Digital-Technologie für die ganze URMA Feinbohrkopf-Familie von Ø 0.2 bis 2'400 mm

- nur ein Anzeigergerät für die ganze DigiTec-Familie
- kein Wartungsaufwand und geringes Ausfallrisiko, da Batterien und Display im Anzeigergerät sind.
- sehr gutes Preis-Leistungsverhältnis
- Nachrüsten der Feinbohrköpfe neuester Generation möglich - ab der Version 2011

Digital-Technology for the entire URMA fine boring head family from Ø 0.2 up to 2'400 mm

- only one control unit for the entire DigiTec family
- no maintenance and minimal risk of failure
- battery and display are located in the handheld control unit.
- excellent price-performance ratio upgrade possible on the fine boring heads - version 2011

Ø 0.2 - 2'400 mm

...auch in der Maschine µ-genau verstellen - einfach und fehlerfrei!

...adjustable in microns, even in the machine - easy and faultless!



weitere Vorteile

- höchste Präzision durch direkte Messung der Verfahrswege
- grosse digitale Anzeige, dadurch keine Einstellfehler
- sichere Handhabung auch bei ungünstigen Lichtverhältnissen (Maschinenraum etc.)
- einfache Umstellung metrisch/Inch sowie Durchmesser/Radius
- Hybrid einsetzbar - funktioniert auch analog über Skalascheibe

Further Advantages

- highest precision through direct measuring of the movement
- large digital display reduces setup error
- safe handling, even under poor lighting conditions (machine tool workspace, etc.)
- easy to switch metric/Inch or Diameter/Radius
- «Hybrid» usage - the boring heads also work conventionally with scale

Ø 7.3 - 25 mm

Werkzeug-Set

Tool-Set



DIGITEC

Inhalt

Content

| Order Number | Beschreibung | Description | Details | Amount |
|-------------------|---------------------------------|-------------------------------------|------------------------------|----------------|
| 05 42 30-D | Feinbohrkopf DigiTec | Fine boring head DigiTec | ø 2-40 mm | 1 |
| H06 06 07 | Hartmetall Bohrstange | Carbide boring bar | ø 7.3-11 mm l = 24-48 mm | 1 |
| HW/C06 10 12 | Hartmetall Bohrstange | Carbide boring bar | ø 11.8-16 mm l = 50-80 mm | 1 |
| W/C06 16 15 | Bohrstange | Boring bar | ø 15-20 l = 45 mm | 1 |
| 07 00 06 | Reduktion | Reducer | ø 6 mm | 1 |
| 07 00 10 | Reduktion | Reducer | ø 10 mm | 1 |
| 06 16 20 | Bohrstange | Boring bar | 20-25 mm l = 60 mm | 1 |
| W/C20 02 06 | Feinbohrplattenhalter | Fine boring insert holder | | 1 |
| C00 20 01 | Ersatzteile (WSP Spannschraube) | Spare parts (insert clamping screw) | | 3 |
| C00 20 10 | Ersatzteile (WSP Spannschraube) | Spare parts (insert clamping screw) | | 3 |
| CPGT060202FXUT150 | Wendeplatte Cermet | Insert cermet | | 10 |
| WCGT020102FYUT150 | Wendeplatte Cermet | Insert cermet | | 10 |
| 92 00 25-D | Anzeigegerät für DigiTec | Display unit for DigiTec | | 1 |
| DIGI 00 05 | Koffer leer | Empty case | | 1 |
| | Aufnahme nach Wahl: | Adapter to choose: | | |
| 05 42 30-D 17 | D10 41 16 | DIN 69871-A/40 | D10 41 16 | DIN 69871-A/40 |
| 05 42 30-D 37 | T10 41 16 | MAS-BT-A/40 | T10 41 16 | MAS-BT-A/40 |
| 05 42 30-D 57 | HSKA10 63 17 | HSK63-A | HSKA10 63 17 | HSK63-A |

Anzeigegerät für digitale Feinbohrköpfe

Display Unit for Digital Fine Boring Heads

Anzeigegerät für DigiTec

Display Unit for DigiTec

| Order Number | L | B | H | kg | Index |
|--------------|-----|----|----|--------|-------|
| 92 00 25-D | 120 | 80 | 25 | 0.185* | • |

* inkl. Batterie
Battery included



SPARE PARTS



9V E-Block
Z92 00 25 12









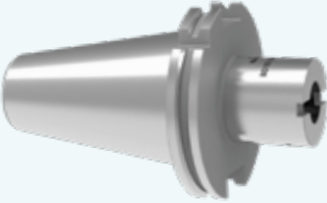

URMA Systems
MicroMax

Ø 0.2 - 40 mm

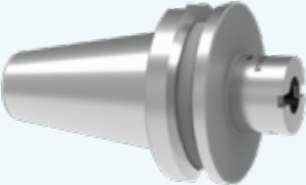
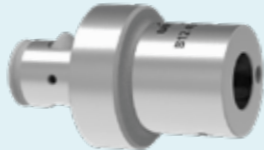
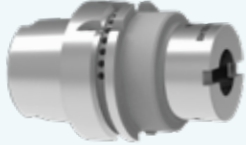
Ø 0.2 - 40 mm

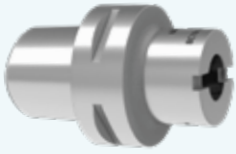
MicroMax

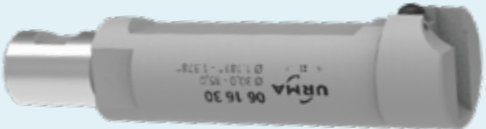
DIGITEC

| | | | | |
|---|---|---|---|---|
| Page 104 - 113 | Page 100 - 101 | From page 22 | Page 24 | Page 24 |
|  |  |  |  |  |
|  |  | | Page 25 | Page 25 |
|  | | |  |  |
|  | | | Page 26 | |
| | | |  | |
| | | | Page 26 | Page 27 |
| | | |  |  |

Ø 0.2 - 40 mm



DIGITEC

Feinbohrkopf 1 µm/Ø *, mit oder ohne Auswuchtmöglichkeit
 Fine Boring Head 1 µm/Ø *, with or without Balancing Features

Feinbohrkopf auswuchtbar
 Fine Boring Head, Balanceable

| Alpha | Order Number | L | D | kg | SW | MCM | MCC | Index |
|-------|--------------|----|----|-----|----|-----|-----|-------|
| 42 | 05 42 30-D | 67 | 42 | 1,3 | 50 | 42 | Z16 | • |
| 42 | 05 42 30 | 67 | 42 | 1,3 | 50 | 42 | Z16 | • |

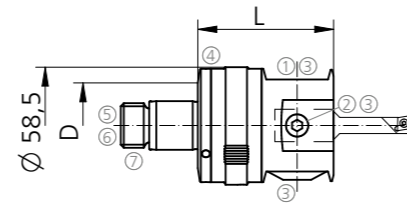

DigiTec Anzeigegerät für digitale Feinbohrköpfe Seite 17
 DigiTec display unit for digital fine boring heads page 17

Feinbohrkopf nicht auswuchtbar
 Non balanceable fine boring head

| Alpha | Order Number | L | D | kg | SW | MCM | MCC | Index |
|-------|--------------|----|----|-----|----|-----|-----|-------|
| 42 | 05 42 40-D | 38 | 42 | 0,7 | 50 | 42 | Z16 | • |
| 42 | 05 42 40 | 38 | 42 | 0,7 | 50 | 42 | Z16 | • |

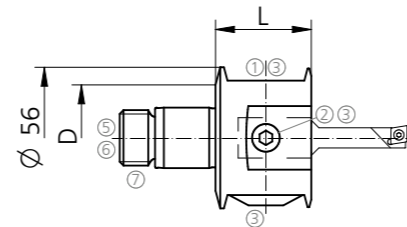

DigiTec Anzeigegerät für digitale Feinbohrköpfe Seite 17
 DigiTec display unit for digital fine boring heads page 17

SPARE PARTS

| Alpha | 1 | 2 | 3 | 4 | 5 | 6 | 7 |
|-------|-----------|-----------|-----------|-----------|-----------|-----------|-----------|
| 42 | Z00 05 01 | Z00 23 01 | G00 02 06 | G00 02 03 | G00 02 04 | G00 02 07 | Z00 22 42 |

Ø 0.2 - 40 mm



DIGITEC

Feinbohrkopf 1 µm/Ø *, mit oder ohne Auswuchtmöglichkeit
 Fine Boring Head 1 µm/Ø *, with or without Balancing Features

Feinbohrkopf auswuchtbar
 Fine Boring Head, Balanceable

| Beta | Order Number | L | D | kg | MCM | MCC | Index |
|------|-----------------|----|----|-----|-----|-----|-------|
| 40 | B05 40 30 067-D | 67 | 42 | 1,3 | B40 | Z16 | • |
| 40 | B05 40 30 067 | 67 | 42 | 1,3 | B40 | Z16 | • |

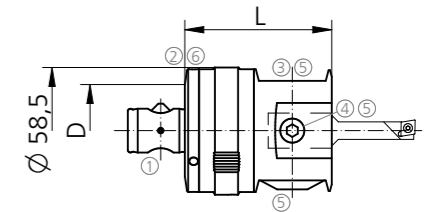

DigiTec Anzeigegerät für digitale Feinbohrköpfe Seite 17
 DigiTec display unit for digital fine boring heads page 17

*** Nur bei DigiTec Version (-D) unter Verwendung des Anzeigegerätes (Seite 17) ansonsten 10 µm/Ø einstellbar**
 Only with DigiTec version (-D) in connection with the display (page 17) otherwise 10 µm/Ø adjustable

SPARE PARTS

| Beta | 1 | 2 | 3 | 4 | 5 | 6 |
|------|-----------|-----------|-----------|-----------|-----------|-----------|
| 40 | Z00 40 21 | Z00 40 23 | Z00 05 01 | Z00 23 01 | G00 02 06 | G00 02 03 |

Ø 0.2 - 6 mm



Bohrstangen

Boring Bars

Reduzierbüchse zu Mini-Bohrstangen

Reducer for Mini-Boring Bars

Ø 0,2 - 6 mm

| Order Number | L | MCM | MCC | Index |
|-----------------|----|-----|------|-------|
| B105.0016.U1.01 | 39 | Z16 | B105 | ● |

Achtung: Schneidrichtung beachten!
Attention: Note the direction of cutting!

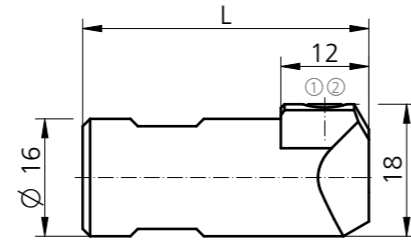

Hartmetall-Mini-Bohrstangen

Carbide Mini-Boring Bars

Ø 0,2 - 6 mm

| Order Number | Ø-Range | L | I | MCM | Index |
|--------------------|-----------|----|-----|------|-------|
| L105.1802.0.02MG12 | 0.2 - 0.8 | 23 | 1,0 | B105 | ● |
| L105.1802.0.03MG12 | 0,3 - 0,9 | 23 | 1,0 | B105 | ● |
| L105.1803.0.07MG12 | 0,7 - 2,3 | 23 | 2,0 | B105 | ● |
| R105.1805.1.1TN35 | 1,0 - 3,4 | 25 | 6,0 | B105 | ● |
| R105.1809.1.2TN35 | 2,0 - 6,0 | 25 | 9 | B105 | ● |

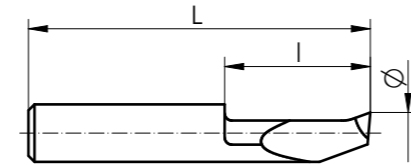

SPARE PARTS

| | | |
|--------|----------|-----------|
| B105.. | ① | ② |
| | | |
| | 6.075T15 | G00 20 03 |

Ø 5.8 - 22.5 mm



Bohrstangen mit Hartmetallschaft für Ausdrehtiefen bis 8xD

Boring Bars with Carbide Shank for Boring Depths up to 8xD

Reduzierbüchsen

Reducers

Ø 5,8 - 22,5 mm

| Order Number | L | D | d | MCM | MCC | Index |
|--------------|----|----|----|-----|------|-------|
| 07 00 05 | 17 | 5 | 16 | Z16 | ZS5 | ● |
| 07 00 06 | 17 | 6 | 16 | Z16 | ZS6 | ● |
| 07 00 08 | 22 | 8 | 19 | Z16 | ZS8 | ● |
| 07 00 10 | 25 | 10 | 22 | Z16 | ZS10 | ● |
| 07 00 12 | 31 | 12 | 22 | Z16 | ZS12 | ● |

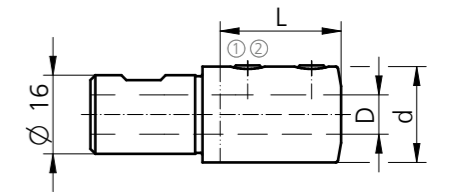

Bohrstangen mit Hartmetallschaft

Boring Bars with Carbide Shanks

Ø 5,8 - 22,5 mm

| Order Number | Ø-Range | L | I | D | Inserts | MCM | MCC | Index |
|--------------|-------------|-----|-------|----|----------------|------|------|-------|
| H06 05 06 | 5,8 - 10 | 65 | 20-40 | 5 | WC.. 0201 | ZS5 | WC02 | ● |
| H06 06 07 | 7,3 - 11 | 70 | 24-48 | 6 | WC.. 0201 | ZS6 | WC02 | ● |
| HW/C06 08 09 | 8,8 - 13 | 90 | 40-64 | 8 | CC../CP.. 0602 | ZS8 | CP06 | ● |
| HW/C06 10 12 | 11,8 - 16 | 105 | 50-80 | 10 | CC../CP.. 0602 | ZS10 | CP06 | ● |
| HW/C06 12 14 | 13,8 - 18 | 120 | 60-96 | 12 | CC../CP.. 0602 | ZS12 | CP06 | ● |
| HW/C06 16 16 | 15,8 - 20 | 130 | 100 | 16 | CC../CP.. 0602 | ZS16 | CP06 | ● |
| HW/C06 16 18 | 18,3 - 22,5 | 145 | 115 | 16 | CC../CP.. 0602 | ZS16 | CP06 | ● |

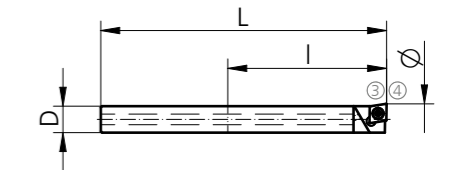

Plattenhalter mit Kombi-Plattensitz siehe Seite 27

Insert holder with combined insert pocket see page 27

SPARE PARTS

| D | ① | ② | ③ | ④ |
|-------|-----------|-----------|-----------|-----------|
| | | | | |
| 5-6 | C00 07 01 | G00 02 03 | C00 20 10 | G00 20 01 |
| 8-10 | C00 25 03 | G00 02 04 | C00 20 04 | G00 20 05 |
| 10-12 | C00 07 02 | G00 02 04 | C00 20 01 | G00 20 05 |
| 16 | | | C00 20 01 | G00 20 05 |

Ø 10 - 40 mm



Bohrstangen mit Stahlschaft
Boring Bars with Steel Shank

Bohrstangen Ø 10 - 20 mm
Boring Bars

| Order Number | Ø-Range | L | I | D | Inserts | MCM | MCC | Index |
|--------------|---------|----|----|------|------------------|-----|------|-------|
| W/C06 16 10 | 10 - 15 | 38 | 35 | 8 | CC../CP.. 0602.. | Z16 | CP06 | ● |
| W/C06 16 15 | 15 - 20 | 48 | 45 | 12,5 | CC../CP.. 0602.. | Z16 | CP06 | ● |
| W06 16 10 | 10 - 15 | 38 | 35 | 8 | CC.. 0602.. | Z16 | CC06 | ● |
| W06 16 15 | 15 - 20 | 48 | 45 | 12,5 | CC.. 0602.. | Z16 | CC06 | ● |

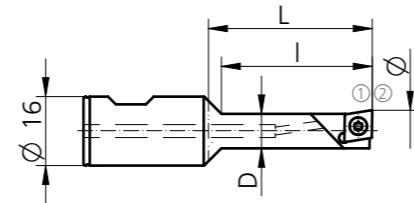

Bohrstangen Ø 20 - 40 mm
Boring Bars

| Order Number | Ø-Range | L | I | D | MCM | MCC | Index |
|--------------|---------|----|----|----|-----|------|-------|
| 06 16 20 | 20 - 25 | 60 | 47 | 17 | Z16 | 2002 | ● |
| 06 16 25 | 25 - 30 | 75 | 62 | 22 | Z16 | 2002 | ● |
| 06 16 30 | 30 - 35 | 75 | 62 | 27 | Z16 | 2002 | ● |
| 06 16 35 | 35 - 40 | 75 | 62 | 32 | Z16 | 2002 | ● |

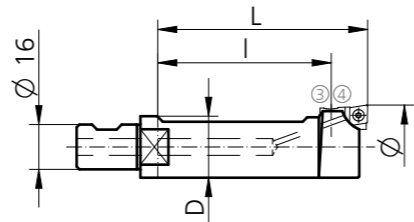

SPARE PARTS

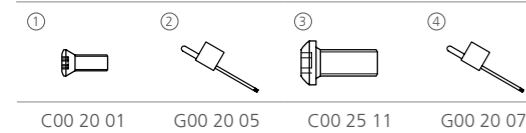

Ø 10 - 40 mm



Plattenhalter
Insert Holders

Plattenhalter Ø 20 - 40 mm
Insert Holders

| Order Number | L | Inserts | MCM | MCC | Index |
|--------------|----|-------------------|------|------|-------|
| W/C20 02 06 | 13 | CC../CP.. 0602.. | 2002 | CP06 | ● |
| W20 02 06 | 13 | CC.. 0602.. | 2002 | CC06 | ● |
| VW20 02 06 | 13 | Wiper CC.. 0602.. | 2002 | CC06 | ● |

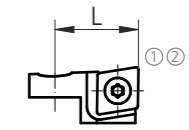

Plattenhalter mit Kombi-Plattensitz
Insert Holder with Combined Insert Pocket

Plattenhalter der Typen W/C... und Bohrstangen HW/C06... sind so ausgelegt, dass sowohl Wendepalten mit 7° (CCGT...) als auch mit 11° Freiwinkel (CPGT...) eingesetzt werden können. Um optimalen Sitz zu gewährleisten, empfehlen wir dringend, auf diesen Plattenhaltern Wendepalten mit engen Umfangstoleranzen zu verwenden (geschliffene CCG... oder CPG... Platten).

Insert holders type W/C... and boring bars HW/C06... are designed to hold inserts with 7° (CCGT...) as well as 11° (CPGT...) clearance angle. We highly recommend to use only precision (ground) inserts (CCG... or CPG...) on such holders to guarantee a perfect fit.

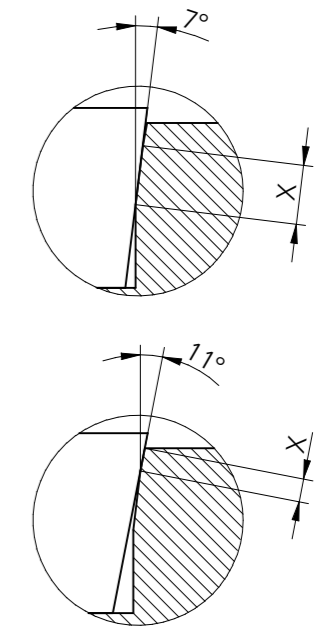

SPARE PARTS

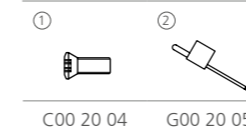

URMA Systems
VersaMax - Type 14

Ø 19.5 - 153 mm

Ø 19.5 - 153 mm

VersaMax - Type 14

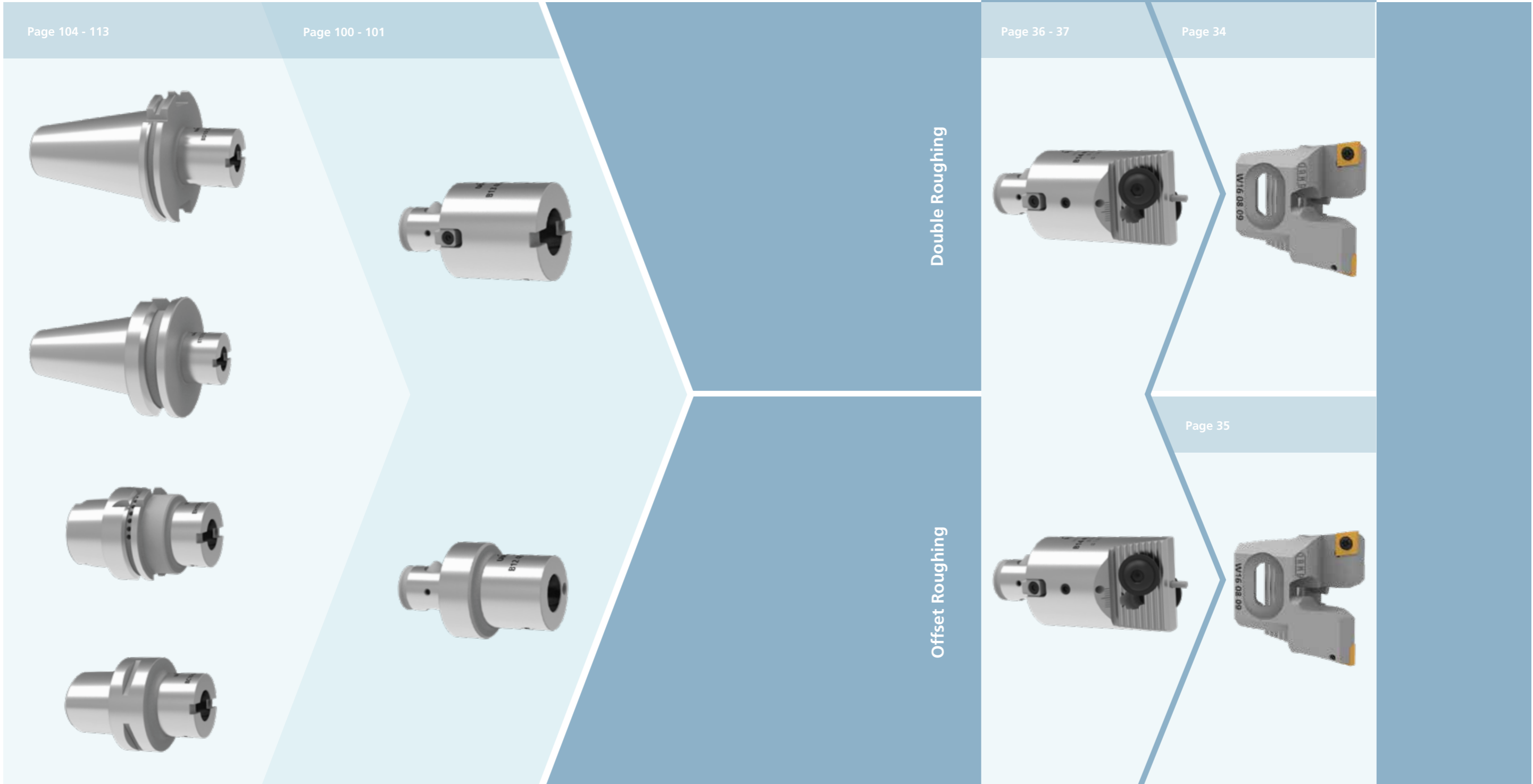

Ø 22.5 - 96 mm

Anfasring
Chamfer Ring

45° Anfasringe
45° Chamfer Rings

| Alpha | Beta | Order Nr. | Ø-Range | L | D ₁ | kg | Inserts | MCM | MCC | Index |
|-------|------|-----------|-----------|----|----------------|-----|--------------|--------|------|-------|
| 18,5 | | W29 00 18 | 22.5 - 33 | 18 | 37 | 0,1 | DC.. 0702.. | 18,5 | DC07 | o |
| 24,5 | | W29 00 24 | 29 - 45 | 22 | 48 | 0,2 | DC.. 0702.. | 24,5 | DC07 | o |
| | 25 | W29 00 25 | 29 - 45 | 22 | 48 | 0,2 | DC.. 07 02.. | B25 | DC07 | o |
| 32 | 32 | W29 00 32 | 38 - 61 | 28 | 64 | 0,4 | DC.. 11T3.. | 32/B32 | DC11 | o |
| 42 | 40 | W29 00 42 | 50 - 72 | 35 | 80 | 0,7 | DC.. 11T3.. | 42/B40 | DC11 | o |
| 55 | | W29 00 55 | 66 - 96 | 42 | 100 | 1,2 | DC.. 11T3.. | 55 | DC11 | o |

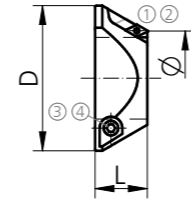

SPARE PARTS

| Alpha | Beta | ① | ② | ③ | ④ |
|-------|------|-----------|-----------|-----------|-----------|
| 18,5 | | C00 20 01 | G00 20 05 | C00 22 05 | G00 02 04 |
| 24,5 | 25 | C00 20 01 | G00 20 05 | C00 22 13 | G00 02 05 |
| 32 | 32 | C00 20 02 | G00 20 03 | C00 22 02 | G00 02 06 |
| 42 | 40 | C00 20 02 | G00 20 03 | C00 26 27 | G00 02 07 |
| 55 | | C00 20 02 | G00 20 03 | C00 22 64 | G00 02 08 |

Ø 19.5 - 153 mm

Vorteile des patentierten URMA Zweischneiderkopfes
Advantages of the Patented URMA Double Cutter Head

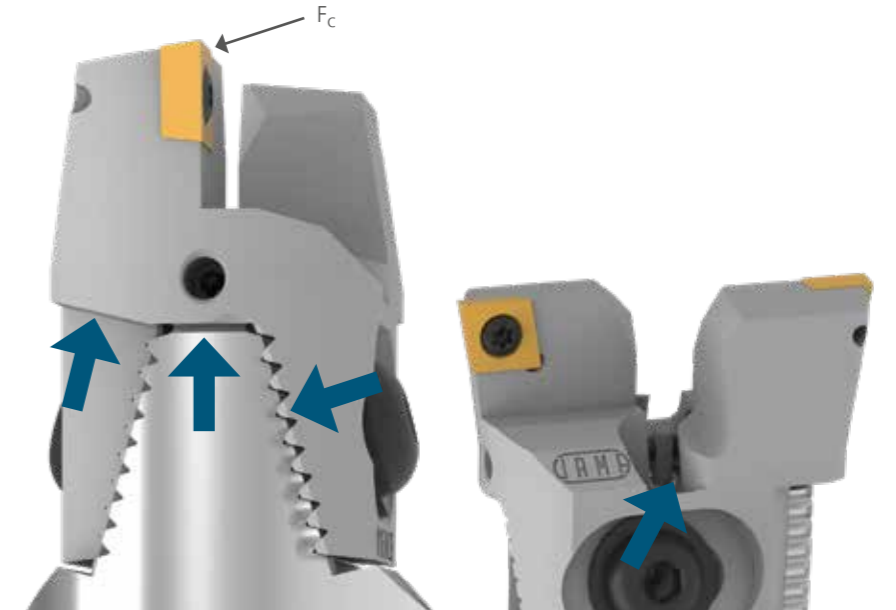

Die patentierte, gegenseitige Abstützung der Plattenhalter leitet die Schnittkräfte (F_c) direkt in den Werkzeugkörper und garantiert höchste Stabilität, Zerspanungsleistung und ermöglicht:

- zweischneidiges Schruppen
- versetztes Schruppen
- individuell verstellbar
- ISO-Wendeplatten
- innere KM-Zuführung
- hohe Zuverlässigkeit
- einfache Handhabung
- nachweisbar höchste Stabilität

Patented design to direct cutting forces (F_c) directly into the body and guarantee highest stability, versatility and allows:

- double cutter roughing
- offset roughing
- individual radial adjustment
- ISO-Standard inserts
- coolant through
- high reliability
- simple handling
- optimized stability

Versetztes Schruppen
Offset Roughing

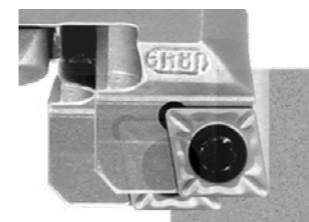

Achsal und radial versetztes Schruppen für grosse Spantiefen
(für den Vorschub pro Minute darf nur mit einer Schneide gerechnet werden, Details Seite 35)

Axial and radial offset roughing for larger cutting depth
(consider only one cutting edge for the feed rate per minute calculation, details page 35)

Ø 19.5 - 153 mm



Plattenhalter

Insert Holders

Plattenhalter 90°

Insert Holders 90°

| Alpha | Beta | Order Number | Ø-Range | kg | Inserts | MCM | MCC | Index |
|-------|------|--------------|-----------|-----|-------------|------|------|-------|
| 18,5 | | W16 01 06 | 19,5 - 25 | 0,1 | CC.. 0602.. | 1418 | CC06 | ● |
| 18,5 | | W16 02 06 | 22,5 - 30 | 0,1 | CC.. 0602.. | 1418 | CC06 | ● |
| 24,5 | 25 | W16 04 06 | 29 - 39 | 0,1 | CC.. 0602.. | 1424 | CC06 | ● |
| 32 | 32 | W16 06 09 | 38 - 51 | 0,1 | CC.. 09T3.. | 1432 | CC09 | ● |
| 42 | 40 | W16 08 09 | 50 - 67 | 0,1 | CC.. 09T3.. | 1442 | CC09 | ● |
| 55 | 63 | W16 10 13 | 66 - 88 | 0,2 | CC.. 1204.. | 1455 | CC12 | ● |
| 55 | 63 | W16 10 12P | 66 - 88 | 0,2 | CN.. 1204.. | 1455 | CN12 | ● |
| 72 | 80 | W16 12 12P | 87 - 116 | 0,5 | CN.. 1204.. | 1472 | CN12 | ● |
| 72 | 80 | W16 12 16P | 87 - 116 | 0,5 | CN.. 1606.. | 1472 | CN16 | ● |
| 94 | 100 | W16 14 16P | 115 - 153 | 1,3 | CN.. 1606.. | 1494 | CN16 | ● |

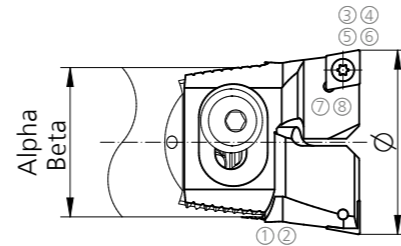

Plattenhalter 75°

Insert Holders 75°

| Alpha | Beta | Order Number | Ø-Range | kg | Inserts | MCM | MCC | Index |
|-------|------|--------------|-----------|-----|-------------|------|------|-------|
| 18,5 | | W18 02 06 | 22,5 - 30 | 0,1 | CC.. 0602.. | 1418 | CC06 | ● |
| 24,5 | 25 | W18 04 06 | 29 - 39 | 0,1 | CC.. 0602.. | 1424 | CC06 | ● |
| 32 | 32 | W18 06 09 | 38 - 51 | 0,1 | CC.. 09T3.. | 1432 | CC09 | ● |
| 42 | 40 | W18 08 09 | 50 - 67 | 0,1 | CC.. 09T3.. | 1442 | CC09 | ● |
| 55 | 63 | W18 10 12P | 66 - 88 | 0,2 | CN.. 1204.. | 1455 | CN12 | ● |
| 72 | 80 | W18 12 16P | 87 - 116 | 0,5 | CN.. 1606.. | 1472 | CN16 | ● |
| 94 | 100 | W18 14 16P | 115 - 153 | 1,3 | CN.. 1606.. | 1494 | CN16 | ● |

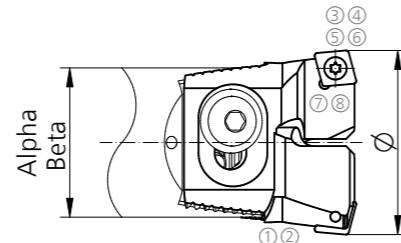

⑦⑧ Im Lieferumfang nicht enthalten

Not included in the delivery

SPARE PARTS

| Alpha | Beta | ① | ② | ③ | ④ | ⑤ | ⑥ | ⑦ | ⑧ |
|-------|------|-----------|-----------|-----------|-----------|-----------|-----------|-----------|-----------|
| 18,5 | | G00 02 01 | C00 02 10 | C00 20 01 | G00 20 05 | | | | |
| 24,5 | 25 | G00 02 01 | C00 02 11 | C00 20 01 | G00 20 05 | | | | |
| 32 | 32 | G00 02 02 | C00 02 12 | C00 20 02 | G00 20 03 | | | | |
| 42 | 40 | G00 02 03 | C00 02 13 | C00 20 02 | G00 20 03 | | | | |
| 55 | 63 | G00 02 03 | C00 02 14 | C00 20 05 | G00 20 03 | | | | |
| 55 | 63 | G00 02 03 | C00 02 14 | | G00 20 03 | A00 12 11 | Z00 12 02 | A00 02 17 | A00 32 07 |
| 72 | 80 | G00 02 04 | C00 02 15 | | G00 20 03 | A00 12 11 | Z00 12 02 | A00 02 17 | A00 32 07 |
| 72 | 80 | G00 02 04 | C00 02 15 | | G00 20 03 | A00 12 12 | Z00 16 03 | A00 02 16 | A00 32 08 |
| 94 | 100 | G00 02 05 | C00 02 16 | | G00 20 03 | A00 12 12 | Z00 16 03 | A00 02 16 | A00 32 08 |

Ø 22.5 - 153 mm



Plattenhalter für versetztes Schruppen

Insert Holders for Offset Roughing

Schneiden in Durchmesser und Höhe versetzt

Gleichmässige Schnittaufteilung

Doppelte Spantiefe bei halbiertem Vorschub

Inserts offset in diameter and height

Equal chip load

Double cutting depth capacity with half the feed rate

Plattenhalter 90°

Insert Holders 90°

| Alpha | Beta | Order Number | Order Number | Ø-Range | kg | Inserts | a _{p max} | x | MCM | MCC | Index |
|-------|------|--------------|--------------|-----------|-----|-------------|--------------------|------|------|------|-------|
| 18,5 | | WV16 02 06 | W16 02 06 | 22,5 - 30 | 0,1 | CC.. 0602.. | 2-3 | 0,2 | 1418 | CC06 | ● |
| 24,5 | 25 | WV16 04 06 | W16 04 06 | 29 - 39 | 0,1 | CC.. 0602.. | 2-3 | 0,2 | 1424 | CC06 | ● |
| 32 | 32 | WV16 06 09 | W16 06 09 | 38 - 51 | 0,1 | CC.. 09T3.. | 3-4 | 0,2 | 1432 | CC09 | ● |
| 42 | 40 | WV16 08 09 | W16 08 09 | 50 - 67 | 0,2 | CC.. 09T3.. | 3-4 | 0,25 | 1442 | CC09 | ● |
| 55 | 63 | WV16 10 12P | W16 10 12P | 66 - 88 | 0,5 | CN.. 1204.. | 4-6 | 0,3 | 1455 | CN12 | ● |
| 72 | 80 | WV16 12 12P | W16 12 12P | 87 - 116 | 1,2 | CN.. 1204.. | 4-6 | 0,3 | 1472 | CN12 | ● |
| 94 | 100 | WV16 14 16P | W16 14 16P | 115 - 153 | 3,0 | CN.. 1606.. | 6-8 | 0,4 | 1494 | CN16 | ● |

Formula $a_p = \frac{D_A - D_i}{4}$

⑦⑧ Im Lieferumfang nicht enthalten

Not included in the delivery

SPARE PARTS

| Alpha | Beta | ① | ② | ③ | ④ | ⑤ | ⑥ | ⑦ | ⑧ |
|-------|------|-----------|-----------|-----------|-----------|-----------|-----------|-----------|-----------|
| 18,5 | | G00 02 01 | C00 02 10 | C00 20 01 | G00 20 05 | | | | |
| 24,5 | 25 | G00 02 01 | C00 02 11 | C00 20 01 | G00 20 05 | | | | |
| 32 | 32 | G00 02 02 | C00 02 12 | C00 20 02 | G00 20 03 | | | | |
| 42 | 40 | G00 02 03 | C00 02 13 | C00 20 02 | G00 20 03 | | | | |
| 55 | 63 | G00 02 03 | C00 02 14 | | G00 20 03 | A00 12 11 | Z00 12 02 | A00 02 17 | A00 32 07 |
| 72 | 80 | G00 02 04 | C00 02 15 | | G00 20 03 | A00 12 11 | Z00 12 02 | A00 02 17 | A00 32 07 |
| 94 | 100 | G00 02 05 | C00 02 16 | | G00 20 03 | A00 12 12 | Z00 16 03 | A00 02 16 | A00 32 08 |

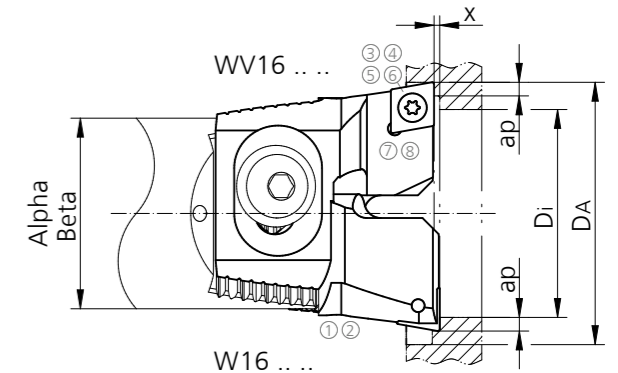

Ø 19.5 - 153 mm



Zweischneiderköpfe

Double Cutter Heads

Zweischneiderköpfe

Double Cutter Heads

| Alpha | Order Number | Ø-Range | L | D | kg | SW | MCM | MCC | Index |
|-------|--------------|-----------|-----|------|-----|----|------|------|-------|
| 18,5 | 14 18 00 | 19,5 - 30 | 40 | 18,5 | 0,1 | 17 | 18,5 | 1418 | ● |
| 24,5 | 14 24 00 | 29 - 39 | 50 | 24,5 | 0,2 | 22 | 24,5 | 1424 | ● |
| 32 | 14 32 00 | 38 - 51 | 65 | 32 | 0,3 | 27 | 32 | 1432 | ● |
| 42 | 14 42 00 | 50 - 67 | 90 | 42 | 0,6 | 36 | 42 | 1442 | ● |
| 55 | 14 55 00 | 66 - 88 | 115 | 55 | 1,3 | 46 | 55 | 1455 | ● |
| 72 | 14 72 00* | 87 - 116 | 150 | 72 | 2,9 | 60 | 72 | 1472 | ● |
| 94 | 14 94 00* | 115 - 153 | 195 | 94 | 6,3 | 75 | 94 | 1494 | ● |

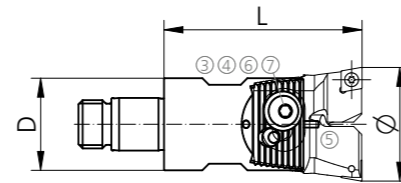

⑨ Im Lieferumfang nicht enthalten
Not included in the delivery

* mit einem Mitnehmerkeil versehen
Supplied with a driving key

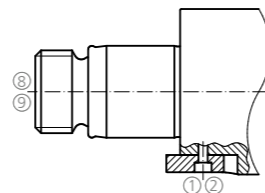

SPARE PARTS

| Alpha | ① | ② | ③ | ④ | ⑤ | ⑥ | ⑦ | ⑧ | ⑨ |
|-------|-----------|-----------|-----------|-----------|-----------|-----------|-----------|----------|---|
| 18,5 | | | | | | | | | |
| 24,5 | | | B00 22 01 | | C00 12 01 | K00 02 01 | G00 20 23 | | |
| 32 | | | B00 22 02 | | C00 12 01 | K00 02 02 | G00 20 24 | | |
| 42 | | | B00 22 03 | G00 02 05 | C00 12 08 | K00 02 03 | | | |
| 55 | | | B00 22 04 | G00 02 06 | C00 12 04 | K00 02 04 | | | |
| 72 | Z00 00 72 | C00 22 11 | B00 22 05 | G00 02 07 | C00 12 05 | K00 02 05 | | | |
| 94 | Z00 00 94 | C00 24 17 | B00 22 06 | G00 02 08 | C00 12 06 | K00 02 06 | Z00 14 74 | 53 74 96 | |
| | | | B00 22 07 | G00 02 10 | C00 12 07 | K00 02 07 | Z00 14 96 | 53 74 96 | |

Ø 29 - 153 mm



Zweischneiderköpfe

Double Cutter Heads

Zweischneiderköpfe

Double Cutter Heads

| Beta | Order Number | Ø-Range | L | D | kg | MCM | MCC | Index |
|------|----------------|-----------|-----|-----|-----|------|------|-------|
| 25 | B14 25 00 050 | 29 - 39 | 50 | 25 | 0,2 | B25 | 1424 | ● |
| 32 | B14 32 00 065 | 38 - 51 | 65 | 32 | 0,3 | B32 | 1432 | ● |
| 40 | B14 40 00 090 | 50 - 67 | 90 | 42 | 0,6 | B40 | 1442 | ● |
| 63 | B14 63 00 100 | 66 - 88 | 100 | 63 | 1,5 | B63 | 1455 | ● |
| 80 | B14 80 00 115 | 87 - 116 | 115 | 80 | 2,5 | B80 | 1472 | ● |
| 100 | B14 100 00 145 | 115 - 153 | 145 | 100 | 4,4 | B100 | 1494 | ● |

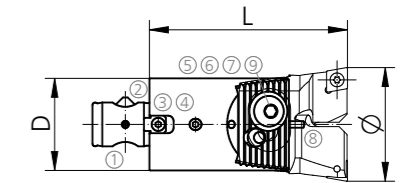

SPARE PARTS

| Beta | ① | ② | ③ | ④ | ⑤ | ⑥ | ⑦ | ⑧ | ⑨ |
|------|------------|------------|------------|-----------|-----------|-----------|-----------|-----------|-----------|
| 25 | | | | | | | | | |
| 32 | Z00 25 21 | Z00 25 23 | | | B00 22 02 | | K00 02 02 | C00 12 01 | G00 20 24 |
| 40 | Z00 32 21 | Z00 32 23 | | | B00 22 03 | G00 02 05 | K00 02 03 | C00 12 08 | |
| 63 | Z00 40 21 | Z00 40 23 | Z00 40 25 | C00 22 58 | B00 22 04 | G00 02 06 | K00 02 04 | C00 12 04 | |
| 80 | Z00 63 21 | Z00 63 23 | Z00 63 25 | C00 22 05 | B00 22 05 | G00 02 07 | K00 02 05 | C00 12 05 | |
| 100 | Z00 80 21 | Z00 80 23 | Z00 80 25 | C00 22 07 | B00 22 06 | G00 02 08 | K00 02 06 | C00 12 06 | |
| | Z00 100 21 | Z00 100 23 | Z00 100 25 | C00 22 71 | B00 22 07 | G00 02 10 | K00 02 07 | C00 12 07 | |

URMA Systems
VersaMax - Type 25 / A25

Ø 18 - 153 mm

Ø 18 - 153 mm

VersaMax - Type 25 / Type A25

DIGITEC

Page 104 - 113

Page 100 - 101

Page 42 - 43

Page 48 - 49

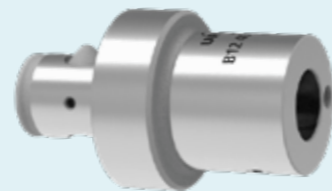
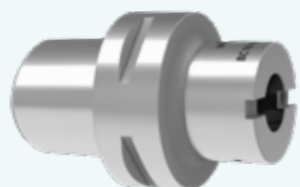
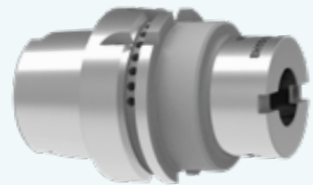
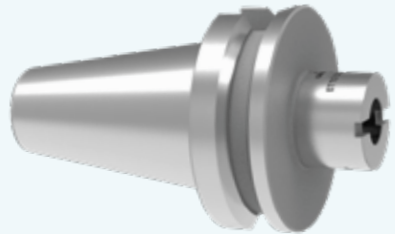
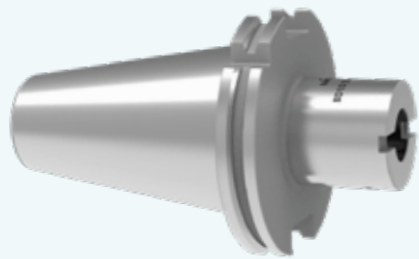

Page 46 - 47



Ø 18 - 153 mm



DIGITEC

Feinbohrköpfe 1 µm/Ø *
Fine Boring Heads 1 µm/Ø *

Feinbohrköpfe
Fine Boring Heads

| Alpha | Order Number | Ø-Range | L | D | d | kg | SW | MCM | MCC | Index |
|-------|--------------|-----------|-----|------|------|-----|----|------|------|-------|
| 24,5 | 25 24 30-D | 29 - 39 | 50 | 26 | 24,5 | 0,2 | 22 | 24,5 | 2002 | ● |
| 32 | 25 32 30-D | 38 - 51 | 65 | 32 | 32 | 0,4 | 27 | 32 | 2004 | ● |
| 42 | 25 42 30-D | 50 - 67 | 90 | 42 | 42 | 1 | 36 | 42 | 2004 | ● |
| 55 | 25 55 30-D | 66 - 88 | 115 | 55 | 55 | 2,2 | 46 | 55 | 2006 | ● |
| 72 | 25 72 30-D | 87 - 116 | 75 | 72 | 72 | 2,5 | 55 | 72 | 2006 | ● |
| 94 | 25 94 30-D | 115 - 153 | 95 | 94 | 94 | 5,2 | 55 | 94 | 2006 | ● |
| 18,5 | 25 16 00 | 18 - 22,5 | 65 | 16 | 18,5 | 0,2 | 17 | 18,5 | 2016 | ● |
| 18,5 | 25 08 00 | 20 - 25 | 40 | 19,7 | 18,5 | 0,1 | 17 | 18,5 | 2002 | ● |
| 18,5 | 25 18 00 | 22,5 - 30 | 40 | 20 | 18,5 | 0,1 | 17 | 18,5 | 2002 | ● |
| 24,5 | 25 24 30 | 29 - 39 | 50 | 26 | 24,5 | 0,2 | 22 | 24,5 | 2002 | ● |
| 32 | 25 32 30 | 38 - 51 | 65 | 32 | 32 | 0,4 | 27 | 32 | 2004 | ● |
| 42 | 25 42 30 | 50 - 67 | 90 | 42 | 42 | 1 | 36 | 42 | 2004 | ● |
| 55 | 25 55 30 | 66 - 88 | 115 | 55 | 55 | 2,2 | 46 | 55 | 2006 | ● |
| 72 | 25 72 30 | 87 - 116 | 75 | 72 | 72 | 2,5 | 55 | 72 | 2006 | ● |
| 94 | 25 94 30 | 115 - 153 | 95 | 94 | 94 | 5,2 | 55 | 94 | 2006 | ● |

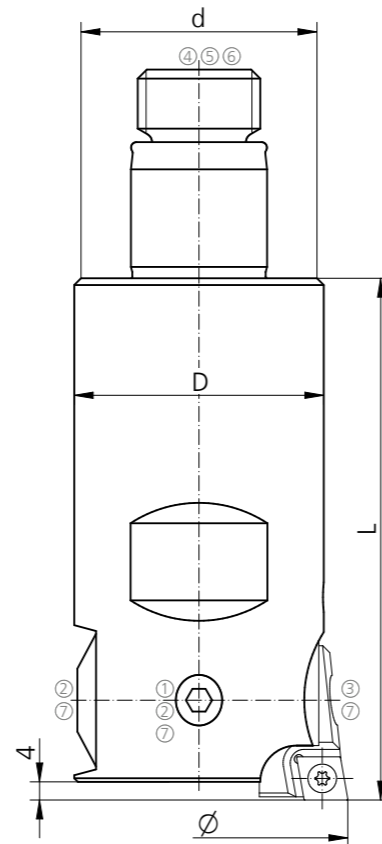

DigiTec Anzeigegerät für digitale Feinbohrköpfe Seite 17
DigiTec display unit for digital fine boring heads page 17

* Nur bei DigiTec Version (-D) unter Verwendung des Anzeigegegerätes (Seite 17) ansonsten 10 µm/Ø einstellbar
Only with DigiTec version (-D) in connection with the display (page 17) otherwise 10 µm/Ø adjustable

SPARE PARTS

| Alpha | Ø-Range | ① | ② | ③ | ④ | ⑤ | ⑥ | ⑦ |
|-------|-----------|-----------|-----------|-----------|-----------|-----------|-----------|-----------|
| 18,5 | 18 - 22,5 | C00 25 18 | | C00 25 19 | G00 02 04 | G00 02 01 | Z00 10 18 | G00 20 02 |
| 18,5 | 20 - 30 | C00 25 01 | | C00 25 11 | G00 02 04 | G00 02 01 | Z00 10 18 | G00 20 07 |
| 24,5 | | C00 25 02 | | C00 25 11 | G00 02 05 | G00 02 02 | Z00 12 24 | G00 20 07 |
| 32 | | C00 25 03 | G00 02 04 | C00 25 12 | G00 02 06 | G00 02 03 | Z00 16 32 | G00 20 03 |
| 42 | | C00 25 04 | G00 02 04 | C00 25 12 | G00 02 07 | G00 02 04 | Z00 22 42 | G00 20 03 |
| 55 | | C00 25 05 | G00 02 06 | C00 25 13 | G00 02 05 | G00 02 08 | Z00 27 55 | |
| 72 | | C00 25 05 | G00 02 06 | C00 25 13 | G00 02 10 | G00 02 08 | Z00 15 74 | |
| 94 | | C00 25 05 | G00 02 06 | C00 25 13 | G00 02 10 | G00 02 08 | Z00 15 96 | |

Ø 29 - 153 mm



DIGITEC

Feinbohrköpfe 1 µm/Ø *
Fine Boring Heads 1 µm/Ø *

Feinbohrköpfe
Fine Boring Heads

| Beta | Order Number | Ø-Range | L | D | d | kg | MCM | MCC | Index |
|------|------------------|-----------|-----|-----|-----|-----|------|------|-------|
| 25 | B25 25 30 050-D | 29 - 39 | 50 | 26 | 25 | 0,2 | B25 | 2002 | ● |
| 32 | B25 32 30 065-D | 38 - 51 | 65 | 32 | 32 | 0,4 | B32 | 2004 | ● |
| 40 | B25 40 30 090-D | 50 - 67 | 90 | 42 | 40 | 1 | B40 | 2004 | ● |
| 63 | B25 63 30 100-D | 66 - 88 | 100 | 63 | 63 | 2,5 | B63 | 2006 | ● |
| 80 | B25 80 30 115-D | 87 - 116 | 115 | 80 | 80 | 4,3 | B80 | 2006 | ● |
| 100 | B25 100 30 145-D | 115 - 153 | 145 | 100 | 100 | 9,2 | B100 | 2006 | ● |
| 25 | B25 25 30 050 | 29 - 39 | 50 | 26 | 25 | 0,2 | B25 | 2002 | ● |
| 32 | B25 32 30 065 | 38 - 51 | 65 | 32 | 32 | 0,4 | B32 | 2004 | ● |
| 40 | B25 40 30 090 | 50 - 67 | 90 | 42 | 40 | 1 | B40 | 2004 | ● |
| 63 | B25 63 30 100 | 66 - 88 | 100 | 63 | 63 | 2,5 | B63 | 2006 | ● |
| 80 | B25 80 30 115 | 87 - 116 | 115 | 80 | 80 | 4,3 | B80 | 2006 | ● |
| 100 | B25 100 30 145 | 115 - 153 | 145 | 100 | 100 | 9,2 | B100 | 2006 | ● |

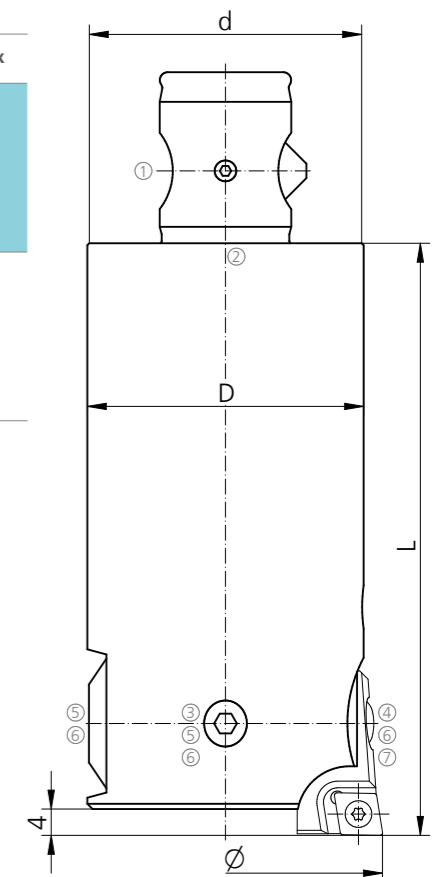

DigiTec Anzeigegerät für digitale Feinbohrköpfe Seite 17
DigiTec display unit for digital fine boring heads page 17

* Nur bei DigiTec Version (-D) unter Verwendung des Anzeigegegerätes (Seite 17) ansonsten 10 µm/Ø einstellbar
Only with DigiTec version (-D) in connection with the display (page 17) otherwise 10 µm/Ø adjustable

SPARE PARTS

| Beta | ① | ② | ③ | ④ | ⑤ | ⑥ | ⑦ |
|------|------------|------------|-----------|-----------|-----------|-----------|-----------|
| 25 | Z00 25 21 | Z00 25 23 | C00 25 02 | C00 25 11 | | G00 20 07 | |
| 32 | Z00 32 21 | Z00 32 23 | C00 25 03 | C00 25 12 | G00 02 04 | G00 20 03 | |
| 40 | Z00 40 21 | Z00 40 23 | C00 25 04 | C00 25 12 | G00 02 04 | G00 20 03 | |
| 63 | Z00 63 21 | Z00 63 23 | C00 25 05 | C00 25 13 | G00 02 06 | | G00 02 05 |
| 80 | Z00 80 21 | Z00 80 23 | C00 25 05 | C00 25 13 | G00 02 06 | | G00 02 05 |
| 100 | Z00 100 21 | Z00 100 23 | C00 25 05 | C00 25 13 | G00 02 06 | | G00 02 05 |

Vorteile ausgewuchteter Feinbohrköpfe Advantages of Balanced Fine Boring Heads

Auswuchtbare Feinbohrköpfe wie der A25 weisen bis zu 100-mal weniger Restunwucht U (gmm) auf gegenüber Standard Feinbohrköpfen und lassen wesentlich höhere Drehzahlen zu! Dabei ist das Auswuchten denkbar einfach, prozesssicher und resultiert in:

- optimale Oberflächenqualität
- geringere Vibrationsneigung
- bessere Rundheit der Bohrung
- höhere Standzeiten

Ein zusätzlicher Kostenaufwand der sich lohnt!

Balancable fine boring heads such as the A25 features up to 100 times less residual imbalance U (gmm) compared to standard fine boring heads and allow remarkably higher revolutions per minute! At the same time the balancing is most simple, reliable and results in:

- best surface quality
- vibration free machining
- better roundness tolerance
- improved tool life

An additional investment that pays back!



Einfache Auswuchtung
Easy to handle balancing

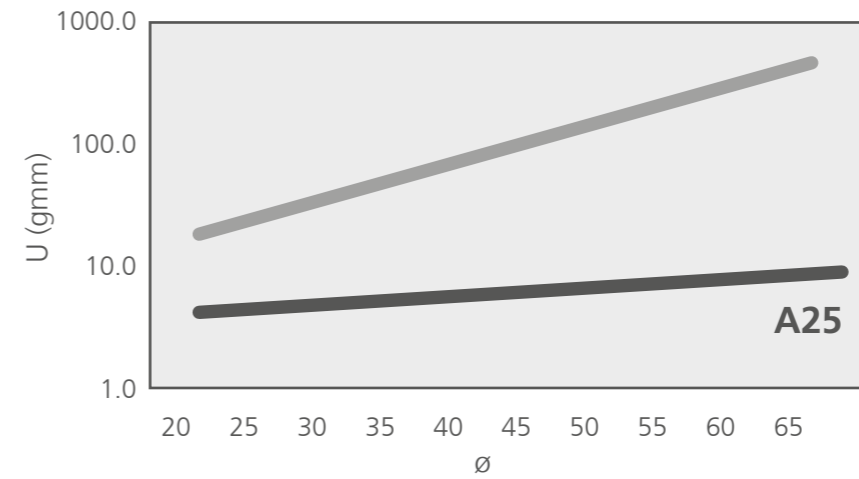

Vergleich A25 zu konventionellem Feinbohrkopf
Comparison A25 to conventional fine boring head

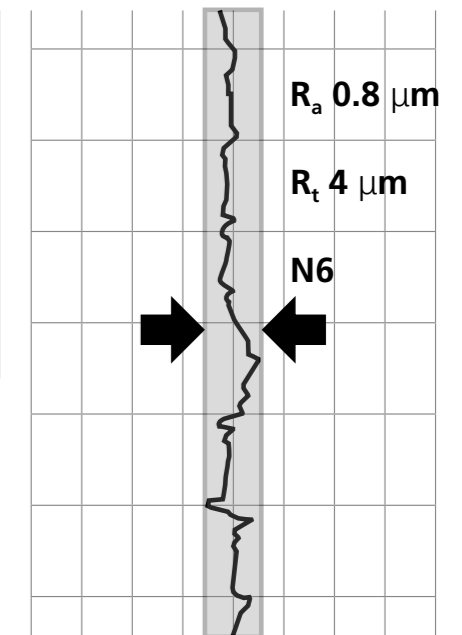

Bessere Oberflächengüte
Better surface quality

Ø 20 - 30 mm



Auswuchtbare Feinbohrköpfe 2 µm/Ø
Balanceable Fine Boring Heads 2 µm/Ø

Feinbohrköpfe
Fine Boring Heads

| Alpha | Order Number | Ø-Range | L | D | d | kg | SW | MCM | MCC | Index |
|-------|--------------|-----------|----|------|------|-----|----|------|------|-------|
| 18,5 | A25 08 00 | 20 - 25 | 40 | 19,7 | 18,5 | 0,1 | 17 | 18,5 | 2002 | ● |
| 18,5 | A25 18 00 | 22,5 - 30 | 40 | 21 | 18,5 | 0,1 | 17 | 18,5 | 2002 | ● |

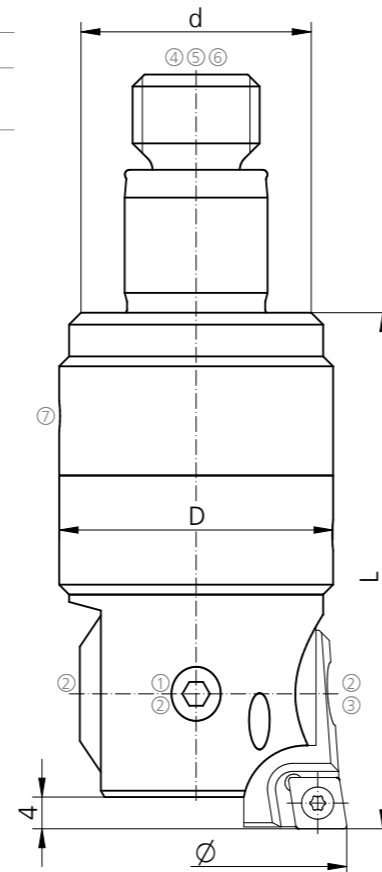

SPARE PARTS

| Alpha | 1 | 2 | 3 | 4 | 5 | 6 | 7 |
|-------|-----------|-----------|-----------|-----------|-----------|-----------|-----------|
| 18,5 | C00 25 01 | G00 20 07 | C00 25 11 | Z00 10 18 | G00 02 01 | G00 02 04 | G00 02 13 |

Ø 29 - 67 mm



Auswuchtbare Feinbohrköpfe 2 µm/Ø
Balanceable Fine Boring Heads 2 µm/Ø

Feinbohrköpfe
Fine Boring Heads

| Beta | Order Number | Ø-Range | L | D | d | kg | MCM | MCC | Index |
|------|---------------|---------|----|------|----|-----|-----|------|-------|
| 25 | A25 25 00 050 | 29 - 39 | 50 | 27 | 25 | 0,2 | B25 | 2002 | ● |
| 32 | A25 32 00 065 | 38 - 51 | 65 | 34,5 | 32 | 0,4 | B32 | 2004 | ● |
| 40 | A25 40 00 090 | 50 - 67 | 90 | 45 | 42 | 1 | B42 | 2004 | ● |

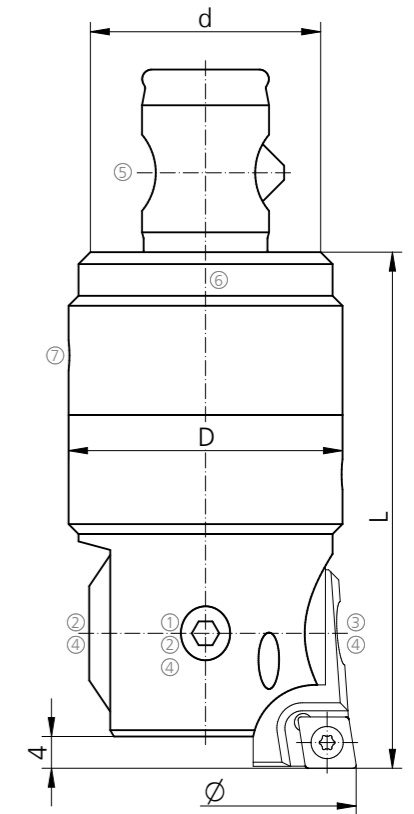

SPARE PARTS

| Beta | 1 | 2 | 3 | 4 | 5 | 6 | 7 |
|------|-----------|-----------|-----------|-----------|-----------|-----------|-----------|
| 25 | C00 25 02 | | C00 25 11 | G00 20 07 | Z00 25 21 | Z00 25 23 | G00 02 01 |
| 32 | C00 25 03 | G00 02 04 | C00 25 12 | G00 20 03 | Z00 32 21 | Z00 32 33 | G00 02 02 |
| 40 | C00 25 04 | G00 02 04 | C00 25 12 | G00 20 03 | Z00 40 21 | Z00 40 23 | G00 02 03 |

Ø 18 - 153 mm



Feinbohr-Plattenhalter
Fine Boring Insert Holders

Kombi-Plattenhalter für ISO Wendepplatten mit 7° und 11° Freiwinkel
Combination Insert Holders for ISO Inserts with 7° and 11° Clearance Angle

| Alpha | Beta | Order Number | Ø-Range | L | Inserts | MCM | MCC | Index |
|-------|------|----------------|-----------|----|------------------|------|------|-------|
| 18,5 | | W/C20 16 00 06 | 18 - 20,5 | 14 | CC../CP.. 0602.. | 2016 | CP06 | ● |
| 18,5 | | W/C20 16 01 06 | 20 - 22,5 | 14 | CC../CP.. 0602.. | 2016 | CP06 | ● |
| 18,5 | | W/C20 02 06 | 20 - 30 | 13 | CC../CP.. 0602.. | 2002 | CP06 | ● |
| 24,5 | 25 | W/C20 02 06 | 29 - 39 | 13 | CC../CP.. 0602.. | 2002 | CP06 | ● |
| 32 | 32 | W/C20 04 06 | 38 - 51 | 17 | CC../CP.. 0602.. | 2004 | CP06 | ● |
| 42 | 40 | W/C20 04 06 | 50 - 67 | 17 | CC../CP.. 0602.. | 2004 | CP06 | ● |
| 55 | 63 | W/C20 06 06 | 66 - 88 | 22 | CC../CP.. 0602.. | 2006 | CP06 | ● |
| 72 | 80 | W/C20 06 06 | 87 - 116 | 22 | CC../CP.. 0602.. | 2006 | CP06 | ● |
| 94 | 100 | W/C20 06 06 | 115 - 153 | 22 | CC../CP.. 0602.. | 2006 | CP06 | ● |

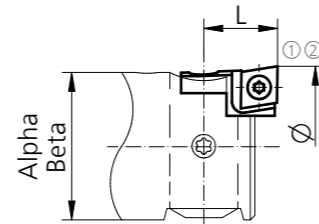

Plattenhalter mit Kombi-Plattensitz siehe Seite 27
Insert holder with combined insert pocket see page 27

Plattenhalter für ISO Wendepplatten mit 7° Freiwinkel
Insert Holders for ISO Inserts with 7° Clearance Angle

| Alpha | Beta | Order Number | Ø-Range | L | Inserts | MCM | MCC | Index |
|-------|------|--------------|-----------|----|-------------|------|------|-------|
| 18,5 | | W20 02 06 | 20 - 30 | 13 | CC.. 0602.. | 2002 | CC06 | ● |
| 24,5 | 25 | W20 02 06 | 29 - 39 | 13 | CC.. 0602.. | 2002 | CC06 | ● |
| 32 | 32 | W20 04 06 | 38 - 51 | 17 | CC.. 0602.. | 2004 | CC06 | ● |
| 42 | 40 | W20 04 06 | 50 - 67 | 17 | CC.. 0602.. | 2004 | CC06 | ● |
| 55 | 63 | W20 06 09 | 66 - 88 | 22 | CC.. 09T3.. | 2006 | CC09 | ● |
| 72 | 80 | W20 06 09 | 87 - 116 | 22 | CC.. 09T3.. | 2006 | CC09 | ● |
| 94 | 100 | W20 06 09 | 115 - 153 | 22 | CC.. 09T3.. | 2006 | CC09 | ● |

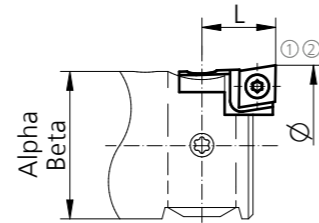

SPARE PARTS

| Order Number | ① | ② |
|--------------|-----------|-----------|
| W/C20 02 06 | C00 20 04 | G00 20 05 |
| W/C20 04 06 | C00 20 01 | G00 20 05 |
| W/C20 06 06 | C00 20 01 | G00 20 05 |
| W20 02 06 | C00 20 04 | G00 20 05 |
| W20 04 06 | C00 20 01 | G00 20 05 |
| W20 06 09 | C00 20 37 | G00 20 03 |

Ø 20 - 153 mm



Feinbohr-Plattenhalter
Fine Boring Insert Holders

Plattenhalter 95° für Wiper Wendepplatten und 7° Freiwinkel
Insert Holders 95° for Wiper Inserts with 7° Clearance Angle

| Alpha | Beta | Order Number | Ø-Range | L | Inserts | MCM | MCC | Index |
|-------|------|--------------|-----------|----|-------------------|------|------|-------|
| 18,5 | | WW20 02 06 | 20 - 30 | 13 | Wiper CC.. 0602.. | 2002 | CC06 | ● |
| 24,5 | 25 | WW20 02 06 | 29 - 39 | 13 | Wiper CC.. 0602.. | 2002 | CC06 | ● |
| 32 | 32 | WW20 04 06 | 38 - 51 | 17 | Wiper CC.. 0602.. | 2004 | CC06 | ● |
| 42 | 40 | WW20 04 06 | 50 - 67 | 17 | Wiper CC.. 0602.. | 2004 | CC06 | ● |
| 55 | 63 | WW20 06 09 | 66 - 88 | 22 | Wiper CC.. 09T3.. | 2006 | CC09 | ● |
| 72 | 80 | WW20 06 09 | 87 - 116 | 22 | Wiper CC.. 09T3.. | 2006 | CC09 | ● |
| 94 | 100 | WW20 06 09 | 115 - 153 | 22 | Wiper CC.. 09T3.. | 2006 | CC09 | ● |

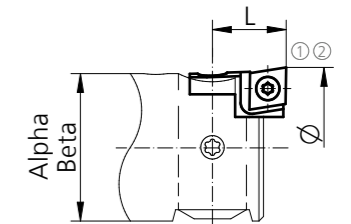

Wiper Wendepplatten
Wiper Inserts

Die Möglichkeiten von Wiper Wendepplatten (doppelter Vorschub bei gleicher Oberflächengüte oder verbesserte Oberflächengüte bei gleichem Vorschub) können nur mit Plattenhaltern mit 95° Anstellwinkel genutzt werden.

The advantages of Wiper inserts (double feed rate at equal surface quality or improved surface quality at equal feed rate) can only be used with insert holders with 95° setting angle.

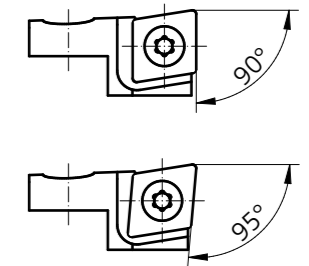

SPARE PARTS

| Order Number | ① | ② |
|--------------|-----------|-----------|
| WW20 02 06 | C00 20 04 | G00 20 05 |
| WW20 04 06 | C00 20 01 | G00 20 05 |
| WW20 06 09 | C00 20 37 | G00 20 03 |

URMA Systems
IntraMax

Ø 49 - 297 mm

Ø 49 - 297 mm

IntraMax

DIGITEC

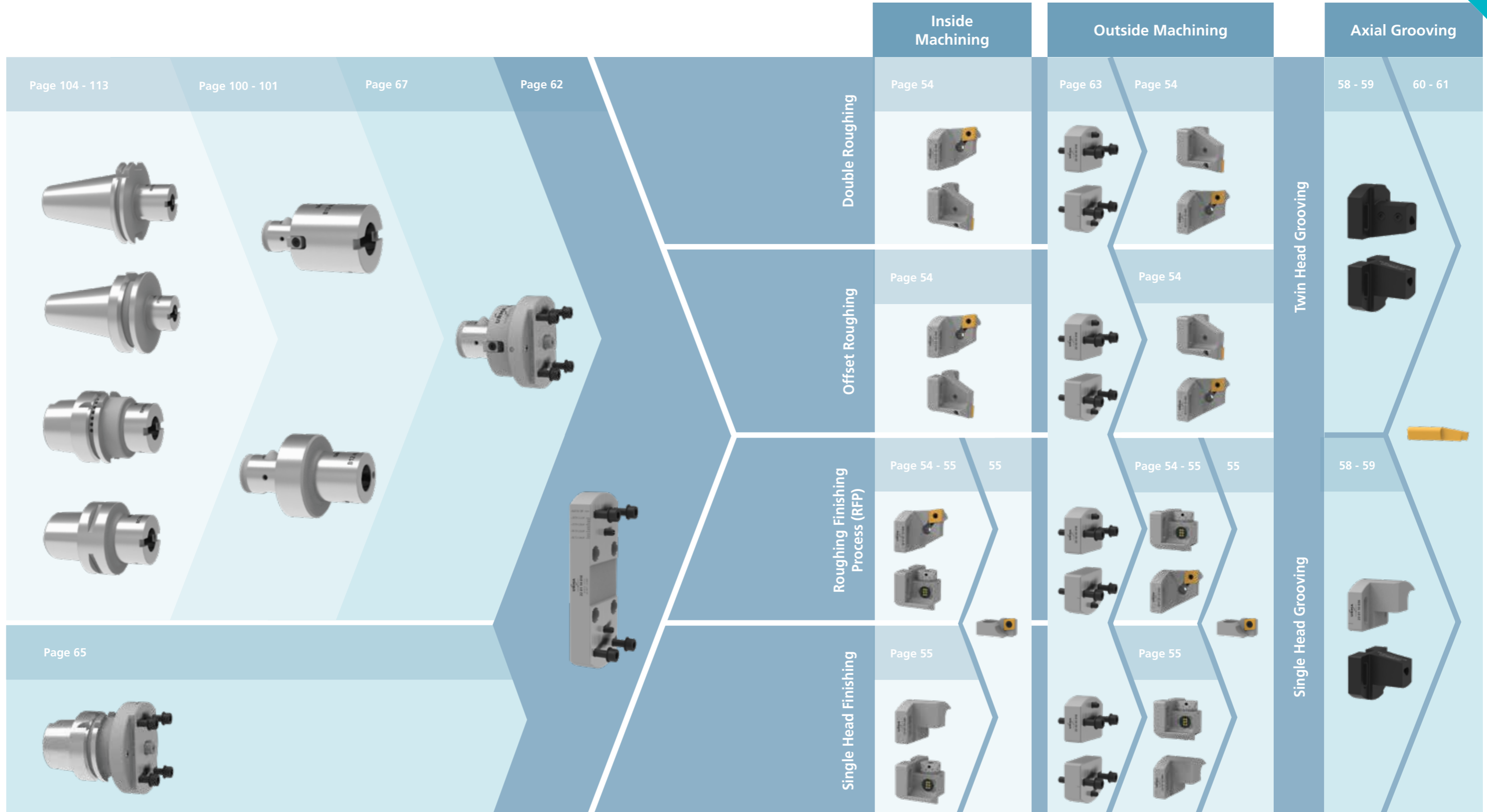

Ø 49 - 297 mm

Plattenhalter Schruppen
Insert Holders Roughing

Für Innen- und Aussenbearbeitung
For Internal and External Machining

Plattenhalter
Insert holders

| Order Number | Ø-Range | L | kg | Inserts | MCM | MCC | Index |
|---------------|----------|----|-----|-------------|--------|------|-------|
| W17 02 09 028 | 49 - 88 | 28 | 0,1 | CC.. 09T3.. | DK2203 | CC09 | ● |
| W17 01 12 040 | 87 - 297 | 40 | 0,3 | CN.. 1204.. | DK2201 | CN12 | ● |

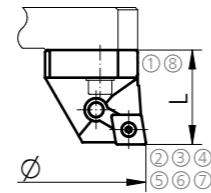

Plattenhalter für versetztes Schruppen
Insert Holder for Offset Roughing

| Order Number | Ø-Range | L | kg | Inserts | a _p | MCM | MCC | Index |
|----------------|----------|------|-----|-------------|----------------|--------|------|-------|
| WW17 01 12 040 | 87 - 297 | 39,7 | 0,3 | CN.. 1204.. | 4 - 6 | DK2201 | CN12 | ● |
| W17 01 12 040 | 87 - 297 | 40 | 0,3 | CN.. 1204.. | 4 - 6 | DK2201 | CN12 | ● |

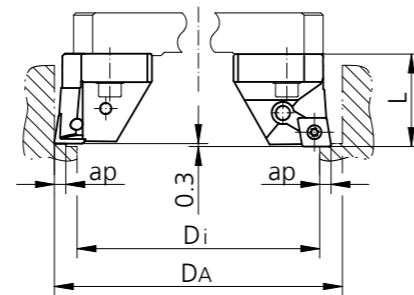

Formula $a_p = \frac{D_a - D_i}{4}$

SPARE PARTS

| | 1 | 2 | 3 | 4 | 5 | 6 | 7 | 8 |
|-------------|-----------|-----------|-----------|-----------|-----------|-----------|-----------|-----------|
| W17 02.. | C00 02 86 | | C00 20 02 | G00 20 03 | | | | G00 02 01 |
| W17 01 (WV) | C00 02 79 | Z00 12 02 | | G00 20 03 | A00 12 11 | A00 02 17 | A00 32 07 | G00 02 02 |

6 7 Im Lieferumfang nicht enthalten
Not included in the delivery

Ø 49 - 297 mm

Feinbohrköpfe
Fine Boring Heads

Für Innen- und Aussenbearbeitung
For Internal and External Machining

Feinbohrköpfe 5 µm/Ø
Fine Boring Heads 5 µm/Ø

| Order Number | Ø-Range | L | l | kg | MCM | MCC | Index |
|----------------|----------|----|----|------|--------|------|-------|
| 23 02 10 028 | 49 - 88 | 28 | 10 | 0,15 | DK2203 | 2012 | ● |
| 23 01 30 040-D | 87 - 297 | 40 | 18 | 0,4 | DK2201 | 2010 | ● |
| 23 01 30 040 | 87 - 297 | 40 | 18 | 0,4 | DK2201 | 2010 | ● |

Bei Verwendung von gleichzeitig 2 Feinbohrköpfen: A_{min} = 53
DigiTec (-D) 1 µm/Ø mit Anzeigegerät (Seite 17)
 When using of 2 heads simultaneously: A_{min} = 53
 DigiTec (-D) 1 µm/Ø with display unit (page 17)

Feinbohrplattenhalter
Fine Boring Insert Holders

| Order Number | Ø-Range | L | Inserts | MCM | MCC | Index |
|----------------|----------|----|-----------------------|------|------|-------|
| WC20 12 06 000 | 49 - 88 | 18 | CP..0602../CC..0602.. | 2012 | CP06 | ● |
| WC20 10 06 000 | 87 - 297 | 22 | CP..0602../CC..0602.. | 2010 | CP06 | ● |
| W20 12 06 000 | 49 - 88 | 18 | CC..0602.. | 2012 | CC06 | ● |
| W20 10 06 000 | 87 - 297 | 22 | CC..0602.. | 2010 | CC06 | ● |
| WW20 12 06 000 | 49 - 88 | 18 | Wiper CC..0602.. | 2012 | CC06 | ● |
| WW20 10 06 000 | 87 - 297 | 22 | Wiper CC..0602.. | 2010 | CC06 | ● |

Gegengewichte
Counter Weights

| Order Number | Ø-Range | L | kg | MCM | Index |
|--------------|----------|----|-----|--------|-------|
| 23 02 10 024 | 49 - 88 | 28 | 0,1 | DK2203 | ● |
| 23 01 10 036 | 87 - 297 | 40 | 0,3 | DK2201 | ● |

SPARE PARTS

| Ø-Range | 1 | 2 | 3 | 4 | 5 | 6 | 7 | 8 | 9 | 10 | 11 |
|----------|-----------|-----------|-----------|-----------|-----------|---|-----------|-----------|-----------|-----------|-----------|
| 49 - 88 | C00 02 86 | C00 22 56 | K00 02 44 | C00 25 01 | Z00 23 02 | | G00 20 07 | G00 02 01 | G00 02 03 | | |
| 87 - 297 | C00 02 79 | C00 22 11 | K00 02 01 | C00 07 01 | Z00 23 02 | | | G00 02 02 | G00 02 03 | G00 02 04 | G00 02 01 |
| W..20 | | | | | | | C00 20 01 | G00 20 05 | | | |

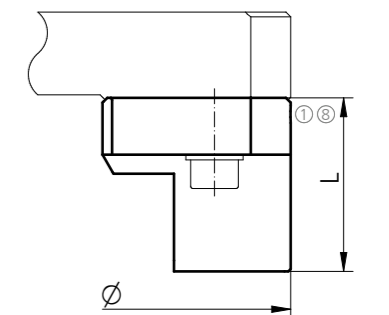
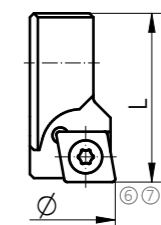
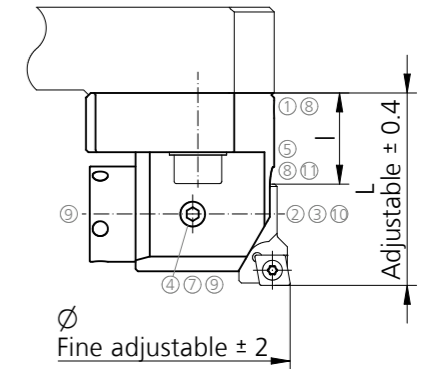

DIGITEC

| | |
|------------------|--------------|
| Ø 49 - 297 mm | IntraMax |
| Ø 150 - 805 mm | MegaMax |
| Ø 500 - 2'400 mm | SuperMegaMax |

Schruppen und Schlichten in einem Arbeitsgang (RFP)

Simultaneous Single-Pass Rough and Finish (RFP)

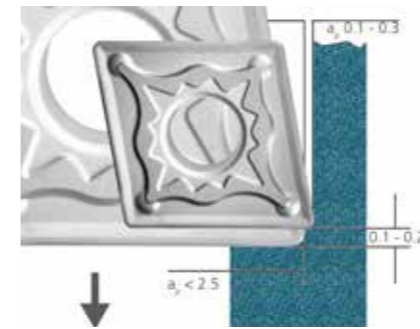

Voreinstellung der beiden Schneiden bei RFP
Presetting of roughing and finishing cutting edge



IntraMax Kombination für RFP
IntraMax RFP combination

Durch den Einsatz von radial und axial versetzten Schneiden kann die Bearbeitungszeit drastisch reduziert werden. Vor- und Fertigbearbeitung werden in einem einzigen Arbeitsgang erledigt. (RFP = Roughing-Finishing-Process)

Das Verfahren kann sowohl auf dem IntraMax als auch auf MegaMax/SuperMegaMax angewendet werden und deckt einen Durchmesserbereich von 49 bis 2'400 mm ab. Empfohlene Spantiefe für den Schrappkopf ist a_p 2,5 mm für Stahl.

Weitere Vorteile:

- geringere Werkzeugkosten
- kürzere Bearbeitungszeit
- hohe Oberflächenqualität
- IT7 in einem Arbeitsgang

Simultaneous single-pass roughing and finishing requires radial and axial boring head offset. Cutting time is dramatically reduced. (RFP = Roughing-Finishing-Process)

On both systems IntraMax and MegaMax/SuperMegaMax RFP can be applied and covers the entire diameter range from 49 to 2'400 mm. Recommended cutting depth on the roughing insert is a_p 2,5 mm for steel.

Further advantages:

- reduced tooling investment
- shorter cutting time
- high surface quality
- IT7 tolerances in one pass

Ø 5 - 45 mm

Achsialeinstechen
Face Grooving



Plattenhalter
Insert Holder

Nut-Aussen
Outer Groove

| Order Number | L | I | B | Type | Index |
|----------------|------|------|------|------|-------|
| BKT105.U90K.01 | 24,5 | 17,5 | 28,5 | R105 | • |

Ab $\varnothing D_{amin} = 2x (6 \text{ mm} + f_{\text{Schneidplatte}})$ sind zwei Plattenhalter gleichzeitig einsetzbar (f siehe Seiten 60 und 61). Für kleinere D_{amin} sind nur ein Plattenhalter mit Gegengewicht möglich.

From $\varnothing D_{amin} = 2x (6 \text{ mm} + f_{\text{insert}})$ two insert holders can be used simultaneously (f see pages 60 and 61). For smaller D_{amin} only one insert holder plus counter weight can be used together.

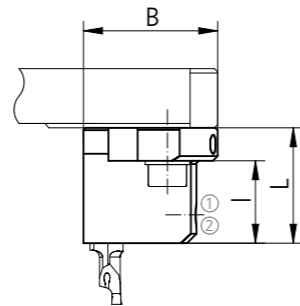

Durchmesserkonsole
Diameter Extender

| Order Number | Ø-Range | Page | Insert holder | Index |
|--------------|---------|---------|----------------|-------|
| 1) | 5 - 18 | 65 - 66 | | • |
| 22 03 06 012 | 18 - 31 | 62 | BKT105.U90K.01 | • |
| 22 03 07 012 | 31 - 45 | 62 | | • |

- 1) **Direkt über Grundaufnahme oder Zwischenkonsole (Seiten 65 - 67)**
Direct via basic holder or intermediate adaptor (pages 65 - 67)

Gegengewicht
Counter Weight

| Order Number | L | I | B | Index |
|---------------|------|------|----|-------|
| 020.U00K.2040 | 24,5 | 17,5 | 22 | • |

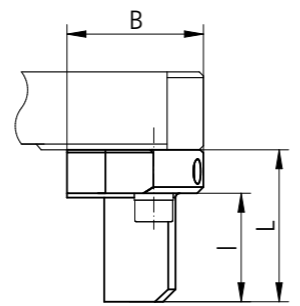

SPARE PARTS

| | | | |
|-------------|----------|------------|--|
| | | | |
| BKT105. ... | 6.075T15 | G00 20 035 | |

Ø 31 - 242 mm

Plattenhalter
Insert Holder

Nut-Aussen
Outer Groove

| Order Number | L | I | B | Type | Index |
|------------------------------|------|------|------|-------|-------|
| BKT105.U90G.01 ¹⁾ | 36,4 | 24,4 | 39,5 | R105 | • |
| BKT110.U17G.02 ²⁾ | 41 | 26 | 39,5 | RA110 | • |

- 1) Ab $\varnothing D_{amin} = 2x (6 \text{ mm} + f_{\text{Schneidplatte}})$ sind zwei Plattenhalter gleichzeitig einsetzbar (f siehe Seiten 60 und 61). Für kleinere D_{amin} sind nur ein Plattenhalter mit Gegengewicht möglich.

From $\varnothing D_{amin} = 2x (6 \text{ mm} + f_{\text{insert}})$ two insert holders can be used simultaneously (f see pages 60 and 61). For smaller D_{amin} only one insert holder plus counter weight can be used together.

- 2) Ab $\varnothing D_{amin} = 2x (13,5 \text{ mm} + f_{\text{Schneidplatte}})$ sind zwei Plattenhalter gleichzeitig einsetzbar (f siehe Seite 61). Für kleinere D_{amin} sind nur ein Plattenhalter mit Gegengewicht möglich.

From $\varnothing D_{amin} = 2x (13,5 \text{ mm} + f_{\text{insert}})$ two insert holders can be used simultaneously (f see page 61). For smaller D_{amin} only one insert holder plus counter weight can be used together.

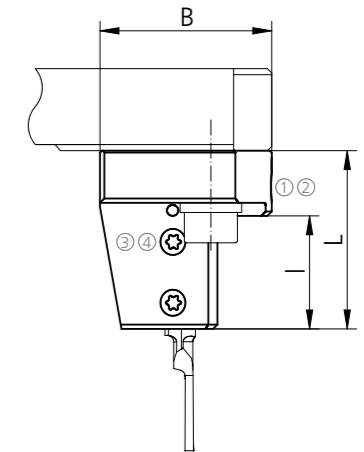

Durchmesserkonsole
Diameter Extender

| Order Number | Ø-Range | Page | Insert holder | Index |
|--------------|-----------|---------|----------------|-------|
| 1) | 31 - 61 | 65 - 66 | | • |
| 22 01 11 018 | 61 - 91 | 62 | | • |
| 22 01 14 018 | 91 - 122 | 62 | BKT105.U90G.01 | • |
| 22 01 17 018 | 122 - 152 | 62 | BKT110.U17G.02 | • |
| 22 01 20 023 | 152 - 182 | 62 | | • |
| 22 01 23 023 | 182 - 212 | 62 | | • |
| 22 01 26 028 | 212 - 242 | 62 | | • |

- 1) **Direkt über Grundaufnahme oder Zwischenkonsole (Seiten 65 - 67)**
Direct via basic holder or intermediate adaptor (pages 65 - 67)

Gegengewicht
Counter Weight

| Order Number | Ø-Range | L | kg | MCM | Index |
|--------------|----------|----|-----|--------|-------|
| 23 01 10 036 | 31 - 242 | 40 | 0,3 | DK2201 | • |

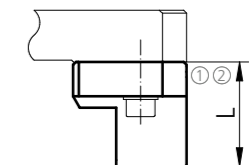

SPARE PARTS

| | | | |
|----------|-----------|-----------|---------------------|
| | | | |
| 31 - 242 | C00 02 79 | G00 02 02 | 6.075T15 G00 20 030 |

Achsialeinstechen (System HORN-URMA)

Face Grooving (System HORN-URMA)



Schneidplatten Typ 105...8

Inserts Type 105...8

| Order Number | W ^{+0.05} | f | r | L | l | t _{max} | D _{min} | Type | HM-Sorten Carbide grades | | Index |
|---------------|--------------------|-----|------|----|----|------------------|------------------|-----------|-----------------------------|------|-------|
| | | | | | | | | | MG12 | TI25 | |
| R105.0510.1.8 | 1,0 | 2,0 | 0,05 | 25 | 10 | 2,0 | 5,0 | BKT105... | ● | ● | ● |
| R105.0515.1.8 | 1,5 | 2,0 | 0,05 | 25 | 10 | 3,0 | 5,0 | BKT105... | ● | ● | ● |
| R105.0520.1.8 | 2,0 | 2,0 | 0,05 | 25 | 10 | 5,0 | 5,0 | BKT105... | ● | ● | ● |
| R105.0510.2.8 | 1,0 | 2,0 | 0,05 | 35 | 15 | 2,0 | 5,0 | BKT105... | ● | ● | ● |
| R105.0515.2.8 | 1,5 | 2,0 | 0,05 | 35 | 15 | 3,0 | 5,0 | BKT105... | ● | ● | ● |
| R105.0520.2.8 | 2,0 | 2,0 | 0,05 | 35 | 15 | 5,0 | 5,0 | BKT105... | ● | ● | ● |
| R105.0610.1.8 | 1,0 | 2,0 | 0,05 | 25 | 10 | 2,0 | 6,0 | BKT105... | ● | ● | ● |
| R105.0615.1.8 | 1,5 | 2,0 | 0,05 | 25 | 10 | 3,0 | 6,0 | BKT105... | ● | ● | ● |
| R105.0620.1.8 | 2,0 | 2,0 | 0,05 | 25 | 10 | 5,0 | 6,0 | BKT105... | ● | ● | ● |
| R105.0610.2.8 | 1,0 | 2,0 | 0,05 | 35 | 15 | 2,0 | 6,0 | BKT105... | ● | ● | ● |
| R105.0615.2.8 | 1,5 | 2,0 | 0,05 | 35 | 15 | 3,0 | 6,0 | BKT105... | ● | ● | ● |
| R105.0620.2.8 | 2,0 | 2,0 | 0,05 | 35 | 15 | 5,0 | 6,0 | BKT105... | ● | ● | ● |
| R105.0810.1.8 | 1,0 | 2,0 | 0,15 | 25 | 10 | 2,0 | 8,0 | BKT105... | ● | ● | ● |
| R105.0815.1.8 | 1,5 | 2,0 | 0,15 | 25 | 10 | 3,0 | 8,0 | BKT105... | ● | ● | ● |
| R105.0820.1.8 | 2,0 | 2,0 | 0,15 | 25 | 10 | 4,0 | 8,0 | BKT105... | ● | ● | ● |
| R105.0825.1.8 | 2,5 | 2,0 | 0,15 | 25 | 10 | 5,0 | 8,0 | BKT105... | ● | ● | ● |
| R105.0830.1.8 | 3,0 | 2,0 | 0,15 | 25 | 10 | 6,0 | 8,0 | BKT105... | ● | ● | ● |
| R105.0810.2.8 | 1,0 | 2,0 | 0,15 | 35 | 15 | 2,0 | 8,0 | BKT105... | ● | ● | ● |
| R105.0815.2.8 | 1,5 | 2,0 | 0,15 | 35 | 15 | 3,0 | 8,0 | BKT105... | ● | ● | ● |
| R105.0820.2.8 | 2,0 | 2,0 | 0,15 | 35 | 15 | 4,0 | 8,0 | BKT105... | ● | ● | ● |
| R105.0825.2.8 | 2,5 | 2,0 | 0,15 | 35 | 15 | 5,0 | 8,0 | BKT105... | ● | ● | ● |
| R105.0830.2.8 | 3,0 | 2,0 | 0,15 | 35 | 15 | 6,0 | 8,0 | BKT105... | ● | ● | ● |

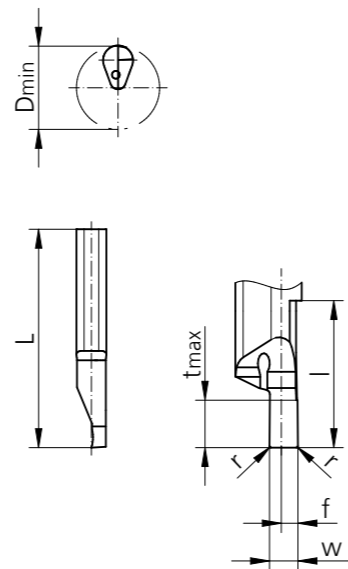

MG12

Unbeschichtetes Hartmetall für tiefe Schnittgeschwindigkeiten in Stahl, Guss und NE-Metallen

TI25

TiCN-beschichtetes Hartmetall für mittlere Schnittgeschwindigkeiten in Stahl und NE-Metallen

Weitere Abmessungen und Schneidenprofile auf Anfrage

MG12

Uncoated carbide for low cutting speed in steel, cast iron and non-ferrous metals

TI25

TiCN coated carbide for medium cutting speed in steel and non-ferrous metals

Further dimension and insert profiles on demand

Schneidplatten Typ 105...9

Inserts Type 105...9

| Order Number | W ^{+0.05} | f | r | L | l | t _{max} | D _{min} | Type | HM-Sorten Carbide grades | | Index |
|---------------|--------------------|-----|------|----|----|------------------|------------------|-----------|-----------------------------|------|-------|
| | | | | | | | | | MG12 | TI25 | |
| R105.0810.1.9 | 1,0 | 0,4 | 0,15 | 25 | 10 | 2,0 | 8,0 | BKT105... | ● | ● | ● |
| R105.0815.1.9 | 1,5 | 0,4 | 0,15 | 25 | 10 | 3,0 | 8,0 | BKT105... | ● | ● | ● |
| R105.0820.1.9 | 2,0 | 0,4 | 0,15 | 25 | 10 | 4,0 | 8,0 | BKT105... | ● | ● | ● |
| R105.0825.1.9 | 2,5 | 0,4 | 0,15 | 25 | 10 | 5,0 | 8,0 | BKT105... | ● | ● | ● |
| R105.0830.1.9 | 3,0 | 0,4 | 0,15 | 25 | 10 | 6,0 | 8,0 | BKT105... | ● | ● | ● |

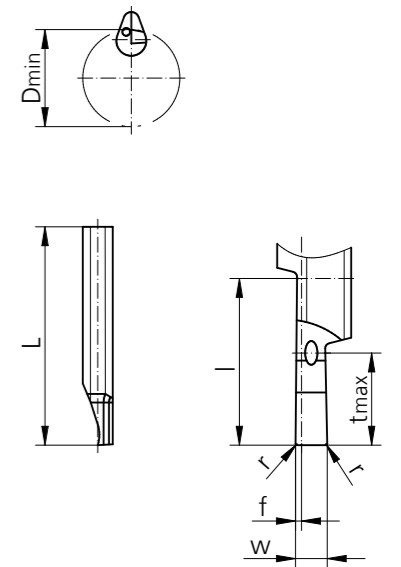

Schneidplatten Typ A110

Inserts Type A110

| Order Number | W ^{+0.05} | f | r | L | t _{max} | D _{min} | Type | HM-Sorten Carbide grades | | Index |
|----------------|--------------------|-----|-----|----|------------------|------------------|-----------|-----------------------------|------|-------|
| | | | | | | | | MG12 | TI25 | |
| RA110.2030.3.0 | 3,0 | 1,5 | 0,2 | 50 | 20 | 20 - 50* | BKT110... | ● | ● | ● |
| RA110.2030.5.0 | 3,0 | 1,5 | 0,2 | 60 | 30 | 20 - 50* | BKT110... | ● | ● | ● |
| RA110.5030.3.0 | 3,0 | 1,5 | 0,2 | 50 | 20 | >50 | BKT110... | ● | ● | ● |
| RA110.5030.5.0 | 3,0 | 1,5 | 0,2 | 60 | 30 | >50 | BKT110... | ● | ● | ● |

* Axialstechen ins Volle bei voller Stechtiefe nur bei D_a = 20 - 50 mm möglich
Face grooving with full width to the full depth only possible between D_a = 20 - 50 mm

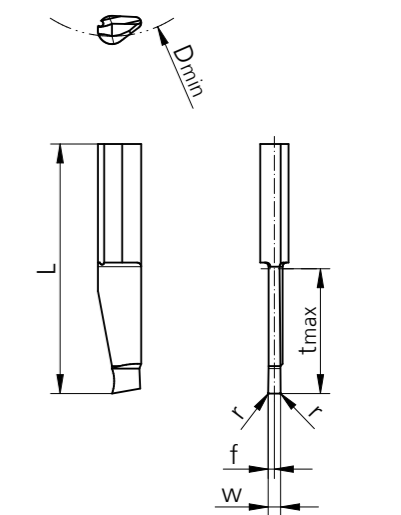

Ø 49 - 297 mm

Durchmesserkonsolen
Diameter Extenders



Durchmesserkonsolen Ø 49 - 88 mm
Diameter Extenders

| Order Number | Ø-Range | L | I | D | kg | MCM | MCC | Index |
|--------------|---------|----|----|----|-----|-------|--------|-------|
| 1) | 49 - 62 | | | | | | | ● |
| 22 03 06 012 | 62 - 75 | 12 | 40 | 59 | 0,2 | Z2203 | DK2203 | ● |
| 22 03 07 012 | 75 - 88 | 12 | 40 | 72 | 0,3 | Z2203 | DK2203 | ● |

- 1) **Direkt über Grundaufnahme oder Zwischenkonsole (Seiten 65 - 67)**
Direct via basic holder or intermediate adaptor (pages 65 - 67)

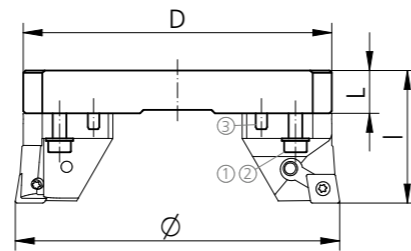

Durchmesserkonsolen Ø 87 - 297 mm
Diameter Extenders

| Order Number | Ø-Range | L | I | D | kg | MCM | MCC | Index |
|--------------|-----------|----|----|-----|-----|-------|--------|-------|
| 1) | 87 - 117 | | | | | | DK2201 | ● |
| 22 01 11 018 | 117 - 147 | 18 | 58 | 110 | 0,8 | Z2201 | DK2201 | ● |
| 22 01 14 018 | 147 - 177 | 18 | 58 | 140 | 1 | Z2201 | DK2201 | ● |
| 22 01 17 018 | 177 - 207 | 18 | 58 | 170 | 1,2 | Z2201 | DK2201 | ● |
| 22 01 20 023 | 207 - 237 | 23 | 63 | 200 | 1,6 | Z2201 | DK2201 | ● |
| 22 01 23 023 | 237 - 267 | 23 | 63 | 230 | 1,9 | Z2201 | DK2201 | ● |
| 22 01 26 028 | 267 - 297 | 28 | 63 | 260 | 2,6 | Z2201 | DK2201 | ● |

- 1) **Direkt über Grundaufnahme oder Zwischenkonsole (Seiten 65 - 67)**
Direct via basic holder or intermediate adaptor (pages 65 - 67)

SPARE PARTS

| Ø-Range | ① | ② | ③ |
|----------|-----------|-----------|-----------|
| 49 - 88 | C00 22 05 | K00 02 01 | C00 12 08 |
| 87 - 297 | C00 22 02 | K00 02 20 | C00 12 61 |

Ø 9 - 249 mm

Zwischenplatten für Aussenbearbeitung
Intermediate Adaptors for External Machining



Zwischenplatte Ø 9 - 35 mm
Intermediate Adaptors

| Order Number | Ø-Range | D | dz | ds | L | lz | lk | kg | Diameter extender | MCM | MCC | Index |
|--------------|---------|----|----|-----------|----|----|----|-----|-------------------|--------|--------|-------|
| 22 04 00 012 | 9 - 22 | 59 | 74 | Ø + 56 mm | 28 | 12 | 12 | 0,1 | 22 03 06 012 | DK2203 | DK2203 | ● |
| 22 04 00 012 | 22 - 35 | 72 | 87 | Ø + 56 mm | 28 | 12 | 12 | 0,1 | 22 03 07 012 | DK2203 | DK2203 | ● |

Zwischenplatte Ø 9 - 249 mm
Intermediate Adaptors

| Order Number | Ø-Range | D | dz | ds | L | lz | lk | kg | Diameter extender | MCM | MCC | Index |
|--------------|-----------|-----|-----|------------|----|----|----|------|-------------------|--------|--------|-------|
| 22 02 00 018 | 9 - 39 | 110 | 125 | Ø + 100 mm | 40 | 18 | 18 | 0,25 | 22 01 11 018 | DK2201 | DK2201 | ● |
| 22 02 00 018 | 39 - 69 | 140 | 155 | Ø + 100 mm | 40 | 18 | 18 | 0,25 | 22 01 14 018 | DK2201 | DK2201 | ● |
| 22 02 00 018 | 69 - 99 | 170 | 185 | Ø + 100 mm | 40 | 18 | 18 | 0,25 | 22 01 17 018 | DK2201 | DK2201 | ● |
| 22 02 00 018 | 99 - 129 | 200 | 215 | Ø + 100 mm | 40 | 18 | 23 | 0,25 | 22 01 20 023 | DK2201 | DK2201 | ● |
| 22 02 00 018 | 129 - 159 | 230 | 245 | Ø + 100 mm | 40 | 18 | 23 | 0,25 | 22 01 23 023 | DK2201 | DK2201 | ● |
| 22 02 00 018 | 159 - 189 | 260 | 275 | Ø + 100 mm | 40 | 18 | 28 | 0,25 | 22 01 26 028 | DK2201 | DK2201 | ● |
| 22 02 00 018 | 189 - 219 | 290 | 305 | Ø + 100 mm | 40 | 18 | 28 | 0,25 | 22 01 29 028 | DK2201 | DK2201 | ● |
| 22 02 00 018 | 219 - 249 | 320 | 335 | Ø + 100 mm | 40 | 18 | 28 | 0,25 | 22 01 32 028 | DK2201 | DK2201 | ● |

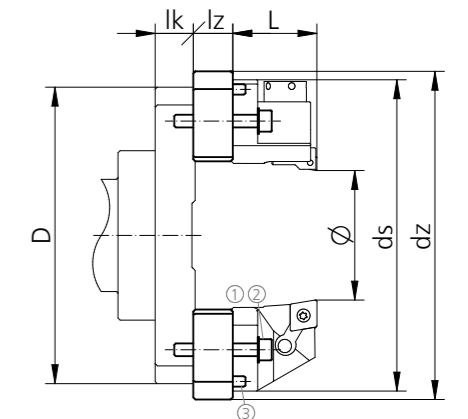

SPARE PARTS

| Ø-Range | ① | ② | ③ |
|---------|-----------|-----------|-----------|
| 9 - 35 | C00 22 05 | K00 02 01 | C00 12 08 |
| 9 - 249 | C00 22 74 | K00 02 20 | C00 12 61 |

Ø 49 - 297 mm

Konsolen direkt
Direct Adaptors



Konsolen direkt
Direct Adaptors

| Order Number | □ | Ø-Range | D | L | kg | MCC | Index |
|---------------|----------|----------|----|----|-----|-------|-------|
| D11 41 03 052 | SK40 / A | 49 - 88 | 46 | 52 | 1,2 | Z2203 | ● |
| H11 43 03 052 | SK40 / B | 49 - 88 | 46 | 52 | 1,2 | Z2203 | ● |
| T11 41 03 052 | MAS-BT40 | 49 - 88 | 46 | 52 | 1,3 | Z2203 | ● |
| HSKA11 63 03 | HSKA-63 | 49 - 88 | 46 | 60 | 1,3 | Z2203 | ● |
| D11 41 01 054 | SK40 / A | 87 - 297 | 80 | 54 | 1,4 | Z2201 | ● |
| H11 43 01 054 | SK40 / B | 87 - 297 | 80 | 54 | 1,4 | Z2201 | ● |
| T11 41 01 054 | MAS-BT40 | 87 - 297 | 80 | 54 | 1,5 | Z2201 | ● |
| HSKA11 63 01 | HSKA-63 | 87 - 297 | 80 | 60 | 1,4 | Z2201 | ● |

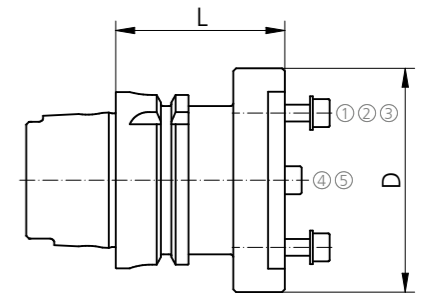

SPARE PARTS

| Ø-Range | ① | ② | ③ | ④ | ⑤ |
|----------|-----------|-----------|-----------|-----------|-----------|
| 49 - 88 | C00 22 05 | K00 02 01 | G00 02 04 | Z00 21 20 | C00 12 08 |
| 87 - 207 | C00 22 02 | K00 02 20 | G00 02 06 | Z00 21 20 | |

Ø 49 - 297 mm

Zwischenkonsolen
Intermediate Adaptors

Modulare Zwischenkonsolen
Intermediate Adaptors

| Alpha | Order Number | Ø-Range | L | D | d | kg | MCM | MCC | Index |
|-------|--------------|----------|----|----|----|-----|-----|-------|-------|
| 42 | 21 42 46 036 | 49 - 88 | 36 | 46 | 42 | 0,5 | 42 | Z2203 | ● |
| 55 | 21 55 80 042 | 87 - 297 | 42 | 80 | 55 | 0,8 | 55 | Z2201 | ● |

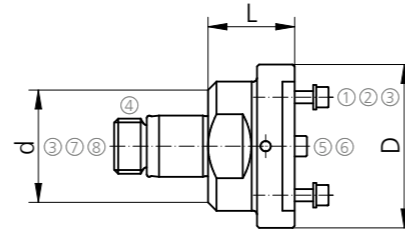

SPARE PARTS

| Ø-Range | ① | ② | ③ | ④ | ⑤ | ⑥ | ⑦ | ⑧ |
|----------|-----------|-----------|-----------|-----------|-----------|-----------|-----------|-----------|
| 49 - 88 | C00 22 05 | K00 02 01 | G00 02 04 | Z00 22 42 | | C00 12 08 | G00 02 07 | |
| 87 - 297 | C00 22 02 | K00 02 20 | G00 02 06 | Z00 27 55 | Z00 21 20 | | G00 02 08 | G00 02 05 |

Ø 49 - 297 mm

Zwischenkonsolen
Intermediate Adaptors

Modulare Zwischenkonsolen
Intermediate Adaptors

| Beta | Order Number | Ø-Range | L | D | d | kg | MCM | MCC | Index |
|------|---------------|----------|----|----|----|-----|-----|-------|-------|
| 40 | B21 40 46 036 | 49 - 88 | 36 | 46 | 42 | 0,5 | B40 | Z2203 | ● |
| 63 | B21 63 80 042 | 87 - 297 | 42 | 80 | 63 | 0,8 | B63 | Z2201 | ● |

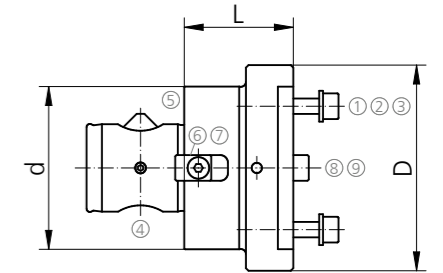

SPARE PARTS

| Ø-Range | ① | ② | ③ | ④ | ⑤ | ⑥ | ⑦ | ⑧ | ⑨ |
|----------|-----------|-----------|-----------|-----------|-----------|-----------|-----------|-----------|-----------|
| 49 - 88 | C00 22 05 | K00 02 01 | G00 02 04 | Z00 40 21 | Z00 40 23 | Z00 40 25 | C00 22 58 | | C00 12 08 |
| 87 - 297 | C00 22 02 | K00 02 20 | G00 02 06 | Z00 63 21 | Z00 63 23 | Z00 63 25 | C00 22 05 | Z00 21 20 | |

URMA Systems
MegaMax

Ø 150 - 805 mm

Ø 150 - 805 mm

MegaMax

DIGITEC

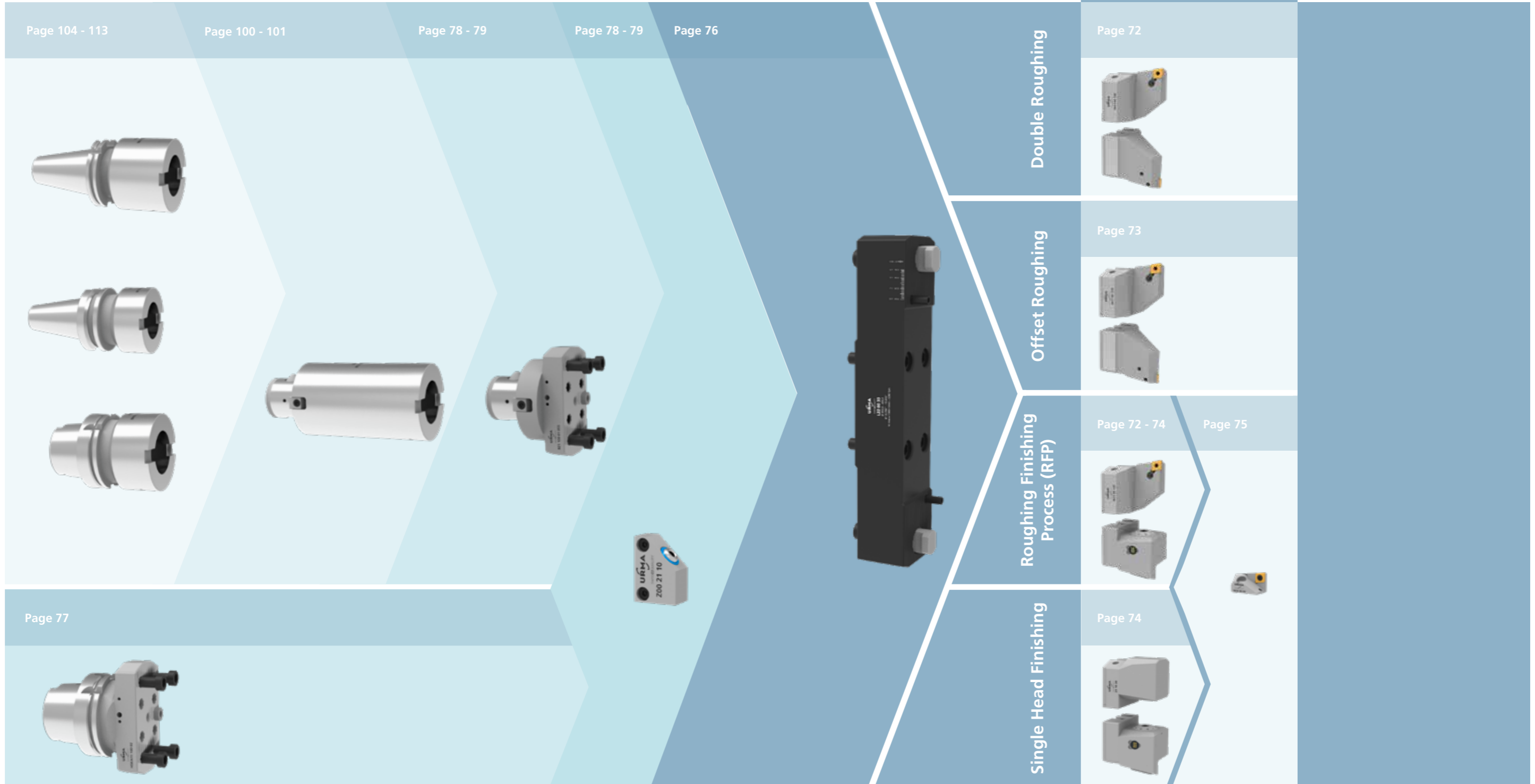

| | |
|------------------|--------------|
| Ø 150 - 805 mm | MegaMax |
| Ø 500 - 2'400 mm | SuperMegaMax |



Plattenhalter
Insert Holders

Plattenhalter 90°
Insert Holders 90°

| Order Number | Ø-Range | L | kg | Inserts | MCM | MCC | Index |
|--------------|------------|----|-----|-------------|-----|------|-------|
| W17 00 12P | 150 - 2400 | 75 | 1,5 | CN.. 1204.. | K00 | CN12 | ● |
| W17 00 16P | 150 - 2400 | 75 | 1,5 | CN.. 1606.. | K00 | CN16 | ● |

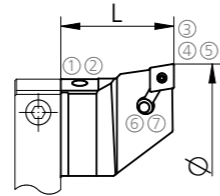

Plattenhalter 90° für Keramik-Wendepplatten
Insert Holders 90° for Ceramic Inserts

| Order Number | Ø-Range | L | kg | Inserts | MCM | MCC | Index |
|--------------|------------|----|-----|-------------|-----|--------|-------|
| K17 00 16 | 150 - 2400 | 75 | 1,5 | CN.. 1607.. | K00 | CN1607 | ● |

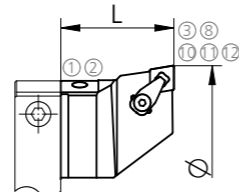

Plattenhalter 75°
Insert Holders 75°

| Order Number | Ø-Range | L | kg | Inserts | MCM | MCC | Index |
|--------------|------------|----|-----|-------------|-----|------|-------|
| W19 00 16P | 150 - 2400 | 75 | 1,5 | CN.. 1606.. | K00 | CN16 | ● |

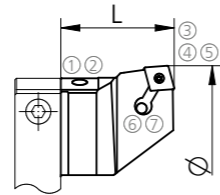

Plattenhalter 75° für Keramik-Wendepplatten
Insert Holders 75° for Ceramic Inserts

| Order Number | Ø-Range | L | kg | Inserts | MCM | MCC | Index |
|--------------|------------|----|-----|-------------|-----|------|-------|
| K19 00 15 | 150 - 2400 | 75 | 1,5 | SN.. 1507.. | K00 | SN15 | ● |

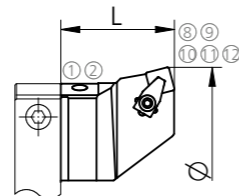

⑥⑦ Im Lieferumfang nicht enthalten
Not included in the delivery

SPARE PARTS

| | | | | | | | | | | | | |
|-------------|-----------|-----------|-----------|-----------|-----------|-----------|-----------|-----------|-----------|-----------|-----------|-----------|
| ① | ② | ③ | ④ | ⑤ | ⑥ | ⑦ | ⑧ | ⑨ | ⑩ | ⑪ | ⑫ | |
| CN.. 1204.. | C00 02 17 | G00 02 06 | A00 12 11 | Z00 12 02 | G00 20 03 | A00 02 17 | A00 32 07 | | | | G00 02 04 | |
| CN.. 1606.. | C00 02 17 | G00 02 06 | A00 12 12 | Z00 16 03 | G00 20 03 | A00 02 16 | A00 32 08 | | | | | |
| CN.. 1607.. | C00 02 17 | G00 02 06 | A00 12 18 | | | | | G00 02 05 | A00 02 15 | A00 42 05 | G00 02 04 | |
| SN.. 1507.. | C00 02 17 | G00 02 06 | | | | | | G00 02 05 | A00 12 06 | A00 02 14 | A00 42 05 | G00 02 04 |

| | |
|------------------|--------------|
| Ø 150 - 805 mm | MegaMax |
| Ø 500 - 2'400 mm | SuperMegaMax |

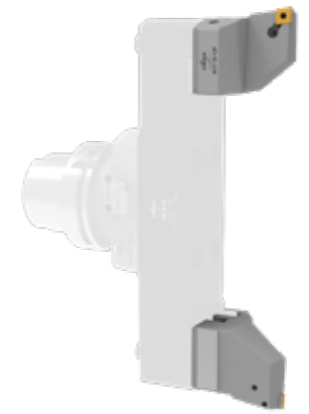

Plattenhalter für versetztes Schruppen
Insert Holders for Offset Roughing

Schneiden in Durchmesser und Höhe versetzt
Gleichmäßige Schnittaufteilung
Doppelte Spantiefe
Inserts offset in diameter and height
Equal chip load
Double cutting depth capacity

Plattenhalter 90°
Insert Holders 90°

| Order Number | Ø-Range | L | kg | Inserts | a _p | MCM | MCC | Index |
|--------------|------------|------|-----|-----------------|----------------|-----|--------|-------|
| W17 00 12P | 150 - 2400 | 75,0 | 1,5 | CN.. 1204.. | 6 | K00 | CN12 | ● |
| WV17 00 12P | 150 - 2400 | 74,5 | 1,5 | CN.. 1204.. | 6 | K00 | CN12 | ● |
| W17 00 16P | 150 - 2400 | 75,0 | 1,5 | CN.. 1606.. | 8 | K00 | CN16 | ● |
| WV17 00 16P | 150 - 2400 | 74,5 | 1,5 | CN.. 1606.. | 8 | K00 | CN16 | ● |
| K17 00 16* | 150 - 2400 | 75,0 | 1,5 | CNMX 1607.. T.. | 8 | K00 | CN1607 | ● |
| KV17 00 16* | 150 - 2400 | 74,5 | 1,5 | CNMX 1607.. T.. | 8 | K00 | CN1607 | ● |

* für keramische Wendeschneidplatten mit Ceramtec Muldenklammung
for ceramic inserts with Ceramtec notch type clamping

Formula
$$a_p = \frac{D_A - D_i}{4}$$

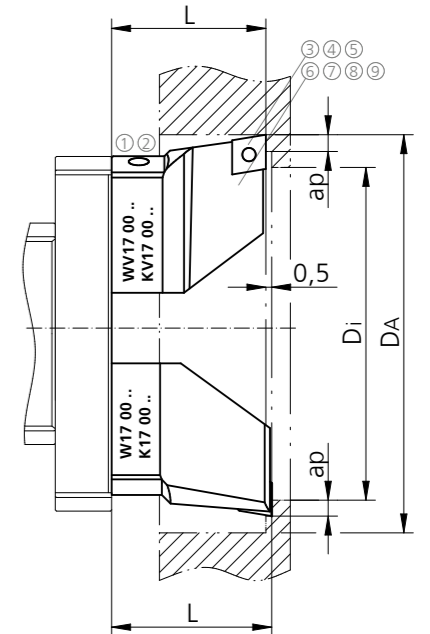

⑥⑦ Im Lieferumfang nicht enthalten
Not included in the delivery

SPARE PARTS

| | | | | | | | | |
|-------------|-----------|-----------|-----------|-----------|-----------|-----------|-----------|-----------|
| ① | ② | ③ | ④ | ⑤ | ⑥ | ⑦ | ⑧ | ⑨ |
| CN.. 1204.. | C00 02 17 | G00 02 06 | A00 12 11 | Z00 12 02 | G00 20 03 | A00 02 17 | A00 32 07 | |
| CN.. 1606.. | C00 02 17 | G00 02 06 | A00 12 12 | Z00 16 03 | G00 20 03 | A00 02 16 | A00 32 08 | |
| CN.. 1607.. | C00 02 17 | G00 02 06 | A00 12 18 | | | | | A00 42 05 |
| | | | | | | | | A00 02 15 |

| | |
|------------------|--------------|
| Ø 150 - 805 mm | MegaMax |
| Ø 500 - 2'400 mm | SuperMegaMax |

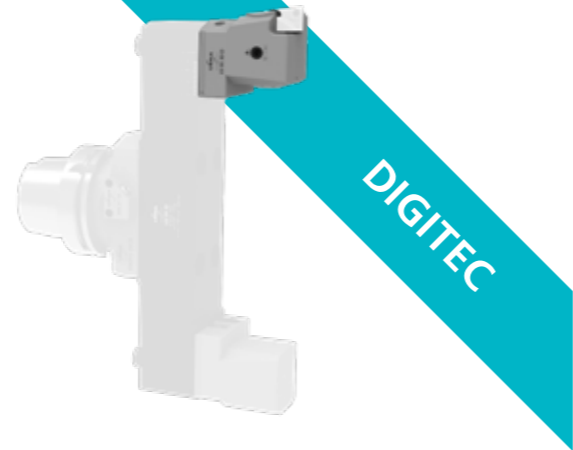

Feinbohrkopf

Fine Boring Head

Feinbohrkopf 1 µm/ø *

Fine Boring Head 1 µm/ø *

| Order Number | Ø-Range | L | I | kg | MCM | MCC | Index |
|--------------|------------|----|----|-----|-----|--------|-------|
| 23 00 30-D | 150 - 2400 | 77 | 42 | 2,3 | K00 | DK2200 | • |
| 23 00 30 | 150 - 2400 | 77 | 42 | 2,3 | K00 | DK2200 | • |

DigiTec Anzeigegerät für digitale Feinbohrköpfe Seite 17

DigiTec display unit for digital fine boring heads page 17

* Nur bei DigiTec Version (-D) unter Verwendung des Anzeigeegerätes (Seite 17) ansonsten 10 µm/ø einstellbar

Only with DigiTec version (-D) in connection with the display (page 17) otherwise 10 µm/ø adjustable

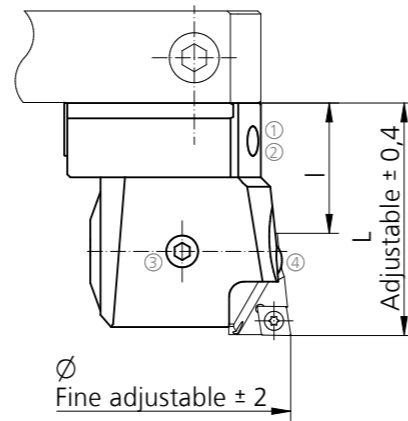

Gegengewicht

Counter Weight

| Order Number | Ø-Range | L | kg | MCM | Index |
|--------------|------------|----|-----|-----|-------|
| 23 10 20 | 150 - 2400 | 64 | 2,3 | K00 | • |

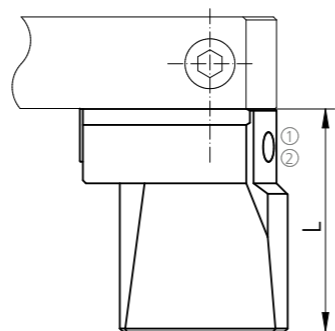

SPARE PARTS

| | | | |
|-----------|-----------|-----------|-----------|
| ① | ② | ③ | ④ |
| | | | |
| C00 02 17 | G00 02 06 | Z00 23 01 | C00 23 01 |

| | |
|------------------|--------------|
| Ø 150 - 805 mm | MegaMax |
| Ø 500 - 2'400 mm | SuperMegaMax |



Feinbohr-Plattenhalter

Fine Boring Insert Holders

Plattenhalter 90°

Insert Holders 90°

| Order Number | Ø-Range | L | Inserts | æ | MCM | MCC | Index |
|--------------|------------|----|------------------|----|--------|------|-------|
| W/C20 00 06 | 150 - 2400 | 34 | CP../CC.. 0602.. | 90 | DK2200 | CP06 | • |
| W20 00 09 | 150 - 2400 | 34 | CC.. 09T3.. | 90 | DK2200 | CC09 | • |
| WW20 00 09 | 150 - 2400 | 34 | WIPER CC.. 09T3 | 95 | DK2200 | CC09 | • |

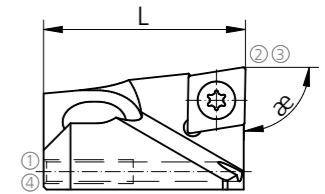

Für gleichzeitiges Schruppen und Schlichten (RFP)

For Simultaneous Roughing and Finishing (RFP)

RFP Plattenhalter 90°

RFP Insert Holders 90°

| Order Number | Ø-Range | L | Inserts | æ | MCM | MCC | Index |
|---------------|------------|----|-----------------|----|--------|------|-------|
| W20 00 09RFP | 150 - 2400 | 31 | CC.. 09T3.. | 90 | DK2200 | CC09 | • |
| WW20 00 09RFP | 150 - 2400 | 31 | WIPER CC.. 09T3 | 95 | DK2200 | CC09 | • |

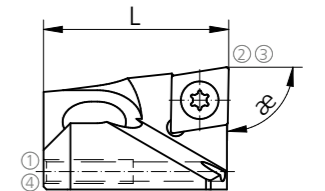

RFP = Roughing-Finishing-Process

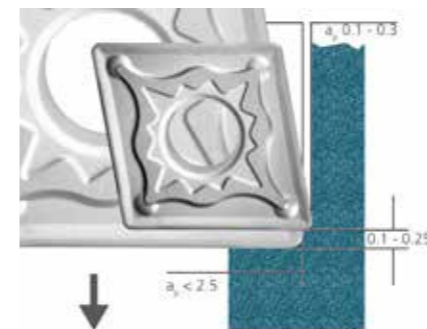

Voreinstellung der beiden Schneiden bei RFP
Beschreibung siehe Seite 57

Presetting of roughing and finishing cutting edge
Description see page 57

Gleichzeitig einsetzbar mit Schrupp-Plattenhalter W17 00 12P (Seite 72)
Simultaneously applicable with roughing insert holder W17 00 12P (page 72)

SPARE PARTS

| | | | |
|------------------|-----------|-----------|-----------|
| ① | ② | ③ | ④ |
| | | | |
| CP../CC.. 0602.. | G00 02 02 | C00 20 01 | G00 20 05 |
| CC.. 09T3.. | G00 02 02 | C00 20 02 | G00 20 03 |
| | | | C00 02 12 |

Ø 150 - 805 mm

Durchmesserkonsolen
Diameter Extenders

Durchmesserkonsolen Stahl
Diameter Extenders Made of Steel

| Order Number | Ø-Range | L | I | D | kg | MCM | MCC | Index |
|--------------|-----------|----|-----|-----|-----|-------|-----|-------|
| Z2 00 13 | 150 - 205 | 30 | 105 | 130 | 1,8 | Z2200 | K00 | ● |
| Z2 00 18 | 200 - 255 | 30 | 105 | 180 | 2,6 | Z2200 | K00 | ● |
| Z2 00 23 | 250 - 305 | 35 | 110 | 230 | 4 | Z2200 | K00 | ● |

weitere Dimensionen auf Anfrage
Further dimensions available on request

Durchmesserkonsolen Aluminium
Diameter Extenders Made of Aluminium

| Order Number | Ø-Range | L | I | D | kg | MCM | MCC | Index |
|--------------|-----------|----|-----|-----|------|-------|-----|-------|
| L22 00 23 | 250 - 305 | 55 | 130 | 230 | 2,8 | Z2200 | K00 | ● |
| L22 00 28 | 300 - 355 | 55 | 130 | 280 | 3,3 | Z2200 | K00 | ● |
| L22 00 33 | 350 - 405 | 55 | 130 | 330 | 3,8 | Z2200 | K00 | ● |
| L22 00 38 | 400 - 455 | 55 | 130 | 380 | 4,3 | Z2200 | K00 | ● |
| L22 00 43 | 450 - 505 | 55 | 130 | 430 | 4,8 | Z2200 | K00 | ● |
| L22 00 48 | 500 - 555 | 65 | 140 | 480 | 6,1 | Z2200 | K00 | ● |
| L22 00 53 | 550 - 605 | 65 | 140 | 530 | 6,7 | Z2200 | K00 | ● |
| L22 00 58 | 600 - 655 | 65 | 140 | 580 | 7,3 | Z2200 | K00 | ● |
| L22 00 63 | 650 - 705 | 65 | 140 | 630 | 8,9 | Z2200 | K00 | ● |
| L22 00 68 | 700 - 755 | 65 | 140 | 680 | 9,6 | Z2200 | K00 | ● |
| L22 00 73 | 750 - 805 | 65 | 140 | 730 | 10,2 | Z2200 | K00 | ● |

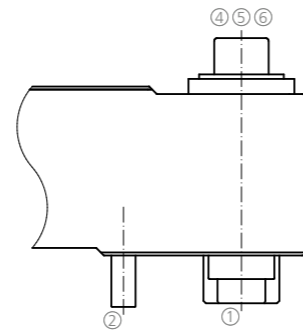
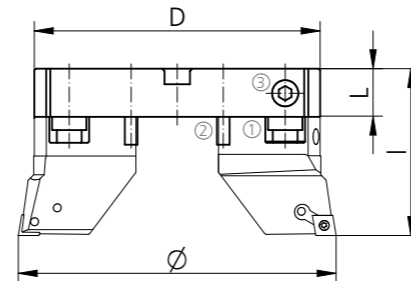

ab Ø = 250
from Ø = 250

SPARE PARTS

| D | ① | ② | ③ | ④ | ⑤ | ⑥ |
|-----------|-----------|-----------|-----------|-----------|-----------|-----------|
| 130-180 | Z00 22 24 | Z00 22 21 | Z00 22 23 | | | |
| 230 steel | Z00 22 16 | Z00 22 21 | | Z00 22 15 | C00 24 04 | K00 02 06 |
| 230-280 | Z00 22 16 | Z00 22 21 | | Z00 22 15 | C00 24 04 | K00 02 06 |
| 480-805 | Z00 22 16 | Z00 22 21 | | Z00 22 15 | C00 26 09 | K00 02 06 |

Ø 150 - 805 mm

Konsolen direkt
Direct Adaptors

DIN 69871-A/D

| Order Number | □ | L | D | kg | MCC | Index |
|--------------|----|----|-----|-----|-------|-------|
| D11 50 02 | 50 | 85 | 130 | 5,6 | Z2200 | ● |

DIN 69871B

| Order Number | □ | L | D | kg | MCC | Index |
|--------------|----|----|-----|-----|-------|-------|
| H11 53 02 | 50 | 85 | 130 | 5,6 | Z2200 | ● |

MAS-BT

| Order Number | □ | L | D | kg | MCC | Index |
|--------------|----|----|-----|-----|-------|-------|
| T11 51 02 | 50 | 88 | 130 | 5,6 | Z2200 | ● |

DIN 69893A HSK

| Order Number | □ | L | D | kg | MCC | Index |
|----------------|-----|----|-----|-----|-------|-------|
| HSKA11 100 02* | 100 | 72 | 130 | 4,4 | Z2200 | ● |

* Kühlmittelrohr ist nicht inbegriffen
Coolant tube is not included

SPARE PARTS

| ① | ② | ③ | ④ | ⑤ |
|-----------|-----------|-----------|-----------|------------|
| Z00 21 02 | C00 22 27 | C00 22 03 | G00 02 19 | H00 100 01 |

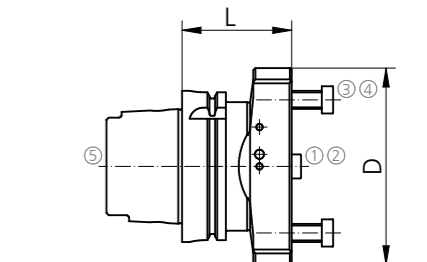
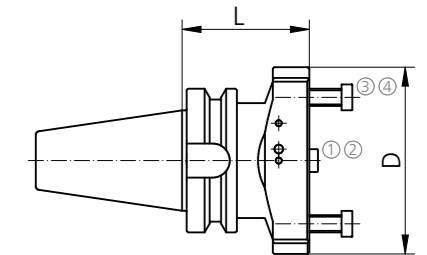
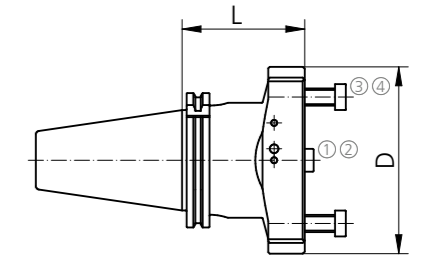
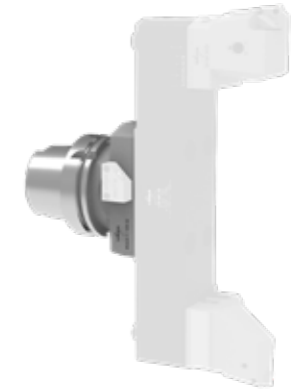

Kühlmitteldüse siehe Seiten 78 und 79
Coolant nozzle see pages 78 and 79

Ø 150 - 805 mm

Konsolenträger
Intermediate Adaptors

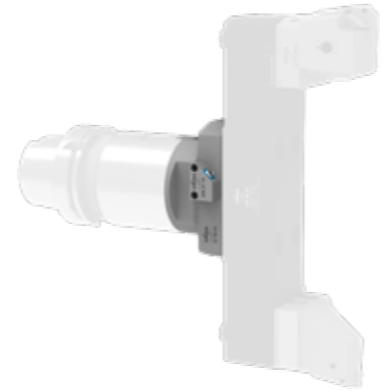

Konsolenträger
Intermediate Adaptors

| Alpha | Order Number | L | D | d | MCM | MCC | Index |
|-------|--------------|----|-----|----|-----|-------|-------|
| 94 | 21 94 01 | 55 | 130 | 94 | 94 | Z2200 | ● |

⑦ **Im Lieferumfang nicht enthalten**
Not included in the delivery

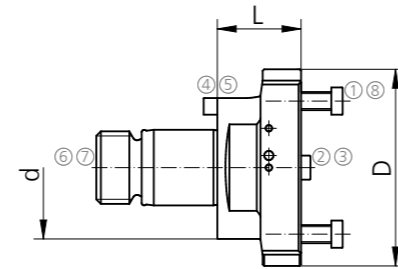

Kühlmitteldüse
Coolant Nozzle

| Alpha | Order Number | MCC | Index |
|-------|--------------|-------|-------|
| 94 | Z00 21 10 | Z0021 | ● |

2 Stück pro Konsolenträger erforderlich
2 pieces per intermediate adaptor necessary

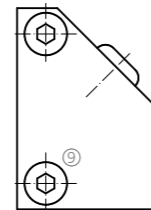

SPARE PARTS

| Alpha | ① | ② | ③ | ④ | ⑤ | ⑥ | ⑦ | ⑧ | ⑨ |
|-------|-----------|-----------|-----------|-----------|-----------|-----------|----------|-----------|-----------|
| 94 | C00 22 03 | Z00 21 02 | C00 22 27 | Z00 00 94 | C00 24 17 | Z00 14 96 | 53 74 96 | G00 02 19 | C00 22 05 |

Ø 150 - 805 mm

Konsolenträger
Intermediate Adaptors



Konsolenträger
Intermediate Adaptors

| Beta | Order Number | L | D | d | kg | MCM | MCC | Index |
|------|----------------|----|-----|-----|-----|------|-------|-------|
| 100 | B21 100 01 055 | 55 | 130 | 100 | 4,7 | B100 | Z2200 | ● |

⑦ **Im Lieferumfang nicht enthalten**
Not included in the delivery

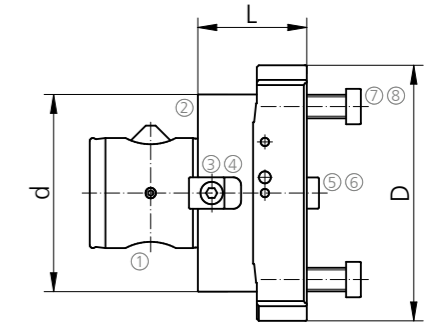

Kühlmitteldüse
Coolant Nozzle

| Beta | Order Number | MCC | Index |
|------|--------------|-------|-------|
| 100 | Z00 21 10 | Z0021 | ● |

2 Stück pro Konsolenträger erforderlich
2 pieces per intermediate adaptor necessary

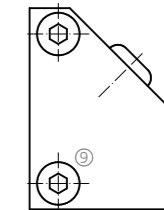

SPARE PARTS

| Beta | ① | ② | ③ | ④ | ⑤ | ⑥ | ⑦ | ⑧ | ⑨ |
|------|------------|------------|------------|-----------|-----------|-----------|-----------|-----------|-----------|
| 100 | Z00 100 21 | Z00 100 23 | Z00 100 25 | C00 22 71 | Z00 21 02 | C00 22 27 | C00 22 03 | G00 02 19 | C00 22 05 |

URMA Systems
SuperMegaMax

Ø 500 - 2'400 mm

Ø 500 - 2'400 mm

SuperMegaMax

DIGITEC

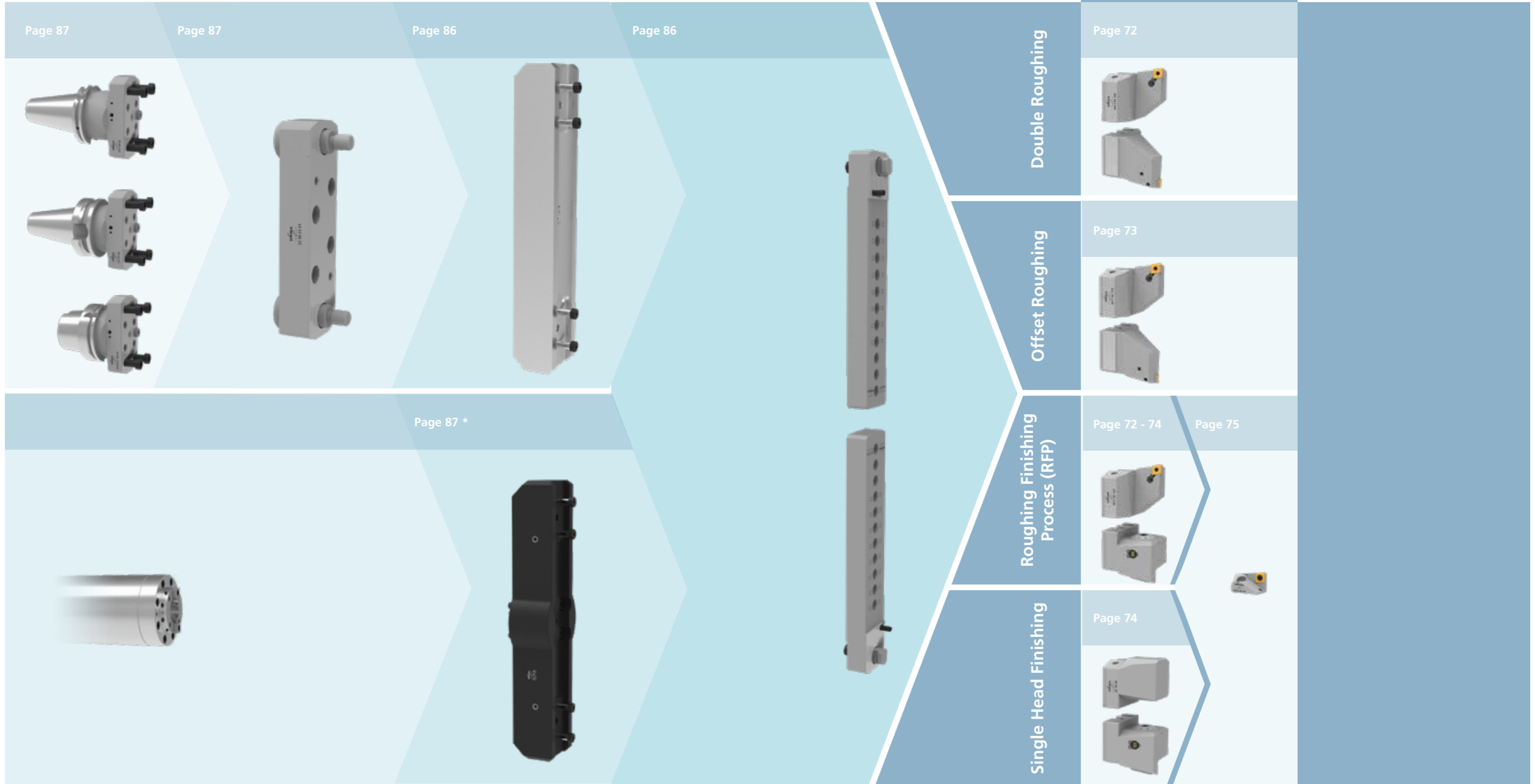

* auf Anfrage; es wird dringend empfohlen, die Werkzeuge auf der Spindelnase zu verschrauben
on request; it is highly recommended to bolt the tools to the spindle nose

Ø 500 - 2'400 mm



Zusammenstellung SuperMegaMax
Assembling SuperMegaMax

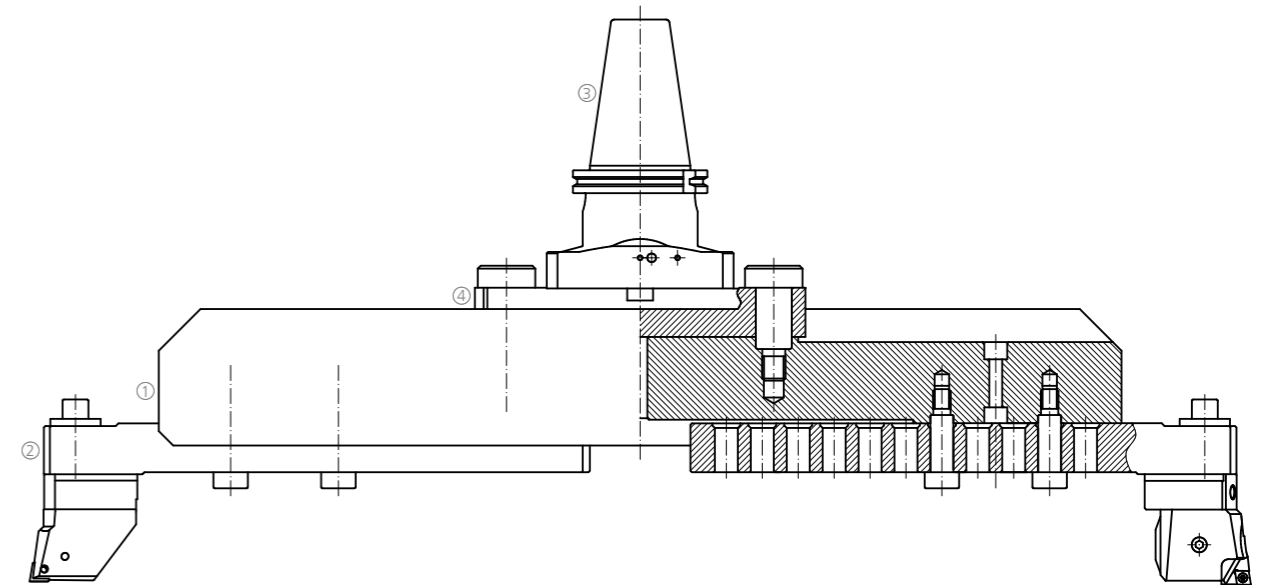

- ① **Konsolenträger (Aluminium)**
Adaptor (aluminium)
- ② **Durchmesserkonsole**
Diameter Extender
- ③ **Grundaufnahme**
Tool Holder
- ④ **Durchmesserkonsole mit Spezialbolzen**
Diameter Extender with Special Lock Stud

Schnittdaten auf Anfrage
Cutting data on request

Ø 500 - 2'400 mm



Konsolenträger / Durchmesserkonsole

Adaptor / Diameter Extender

Konsolenträger (Aluminium)

Adaptor (Aluminium)

| Order Number | Ø-Range | L | I | S | kg | Index |
|--------------|-------------|------|-----|-----|------|-------|
| 21 20 05 * | 500 - 700 | 350 | 50 | 65 | 6 | ● |
| 21 20 07 * | 700 - 900 | 550 | 60 | 75 | 12 | ● |
| 21 20 10 | 800 - 1200 | 670 | 60 | 95 | 17 | ● |
| 21 20 11 | 1200 - 1600 | 1070 | 60 | 95 | 28 | ● |
| 21 20 12 | 1600 - 2000 | 1470 | 115 | 150 | 64 | ● |
| 21 20 13 | 2000 - 2400 | 1870 | 115 | 150 | 81.5 | ● |

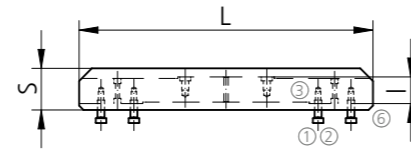

* **Direkt auf Grundaufnahme montiert**
Directly assembled to the tool holder

Durchmesserkonsole

Diameter Extender

| Order Number | Ø-Range | kg | Index |
|--------------|------------|-----|-------|
| 22 00 05 | 500 - 900 | 6.3 | ● |
| 22 20 10 | 800 - 2400 | 8 | ○ |

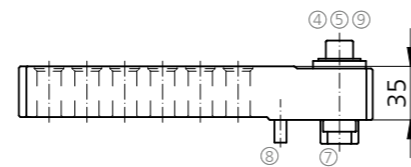

Weitere Angaben zu Plattenhalter S. 72, Anzeigegerät S. 17, Feinbohrköpfe S. 74, Feinbohrplattenhalter S. 75, Ausgleichgewicht S. 74 und Kühlmitteldüse S.78

Information about insert holder p. 72, display unit p. 17, fine boring heads p. 74, fine boring insert holders p. 75, counterweight p. 74 and coolant nozzle p. 78

SPARE PARTS

| | ① | ② | ③ | ④ | ⑤ | ⑥ | ⑦ | ⑧ | ⑨ |
|----------|-----------|-----------|-----------|-----------|-----------|----------|-----------|-----------|-----------|
| 21 20 05 | G00 02 08 | C00 23 02 | | | | | | | |
| 21 20 07 | G00 02 08 | C00 23 02 | | | | | | | |
| 21 20 10 | G00 02 08 | C00 23 02 | | | | | | | |
| 21 20 11 | G00 02 08 | C00 23 02 | | | | | | | |
| 21 20 12 | G00 02 08 | C00 23 02 | C00 96 13 | C00 23 48 | Z00 21 13 | 22 20 13 | | | |
| 21 20 13 | G00 02 08 | C00 23 02 | C00 96 13 | C00 22 92 | Z00 21 13 | 22 20 13 | | | |
| 22 00 05 | | | | C00 24 04 | Z00 22 15 | | Z00 22 16 | Z00 22 21 | K00 02 06 |
| 22 20 10 | | | | C00 24 04 | Z00 22 15 | | Z00 22 16 | Z00 22 21 | K00 02 06 |

Ø 500 - 2'400 mm



Grundaufnahme / Durchmesserkonsole

Tool Holder / Diameter Extender

Grundaufnahme *

Tool Holder *

| Order Number | Ø-Range | □ | L | D | kg | Index |
|---------------|------------|-------------|-----|----|-----|-------|
| D11 50 02 | 500 - 2400 | DIN 69871 A | 50 | 85 | 130 | 5.6 ● |
| H11 53 02 | 500 - 2400 | DIN 69871 B | 50 | 85 | 130 | 5.6 ● |
| T11 51 02 | 500 - 2400 | MAS-BT | 50 | 88 | 130 | 5.6 ● |
| HSKA11 100 02 | 500 - 2400 | DIN 69893 A | 100 | 72 | 130 | 4.4 ● |

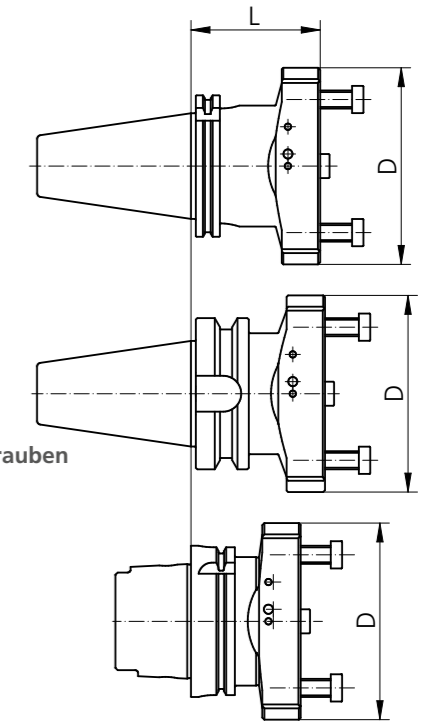

* **Es wird dringend empfohlen, die Werkzeuge auf der Spindelnase zu verschrauben**
Sonderaufnahme und Konsolenträger auf Anfrage
It is highly recommended to bolt the tools to the spindle nose
Adaptors on request

Durchmesserkonsole mit Spezialbolzen

Diameter extender with special lock stud

| Order Number | Ø-Range | L | kg | Index |
|--------------|-------------|----|-----|-------|
| 22 00 23 21 | 800 - 1600 | 35 | 5 | ● |
| 22 00 43 21 | 1600 - 2400 | 40 | 9.7 | ● |

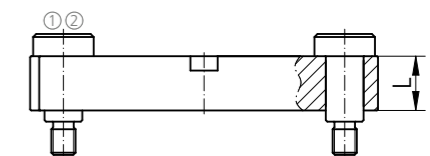

SPARE PARTS

| ① | ② |
|-----------|-----------|
| Z00 21 21 | G00 02 10 |

URMA Systems

LBS-System

Ø 20 - 51 mm

Ø 20 - 51 mm

LBS-System
LBS-System

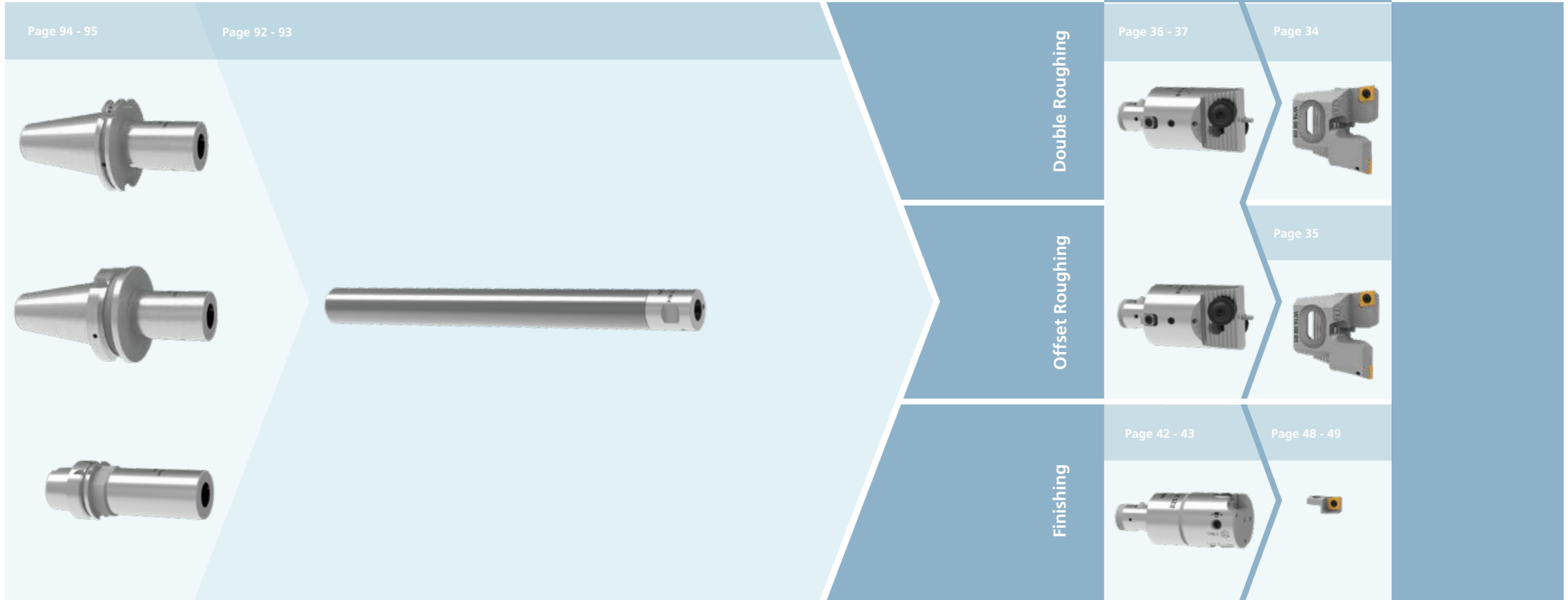

Ø 20 - 51 mm



Hartmetall-Bohrstangen
Carbide Boring Bars

Hartmetall-Bohrstangen
Carbide Boring Bars

| Alpha | Order Number | Ø-Range | L | I | D | kg | SW | MCM | MCC | Index |
|-------|----------------|---------|-----|-----------|------|------|----|--------|------|-------|
| 18,5 | H06 18 A18 200 | 20 - 30 | 200 | 139 - 185 | 18,5 | 0,65 | 17 | ZS18,5 | 18,5 | ● |
| 25 | H06 25 A24 234 | 29 - 39 | 234 | 167 - 209 | 25 | 1,4 | 22 | ZS25 | 24,5 | ● |
| 25 | H06 25 A24 276 | 29 - 39 | 276 | 209 - 251 | 25 | 1,7 | 22 | ZS25 | 24,5 | ● |
| 32 | H06 32 A32 351 | 38 - 51 | 351 | 240 - 320 | 32 | 3,5 | 27 | ZS32 | 32 | ● |

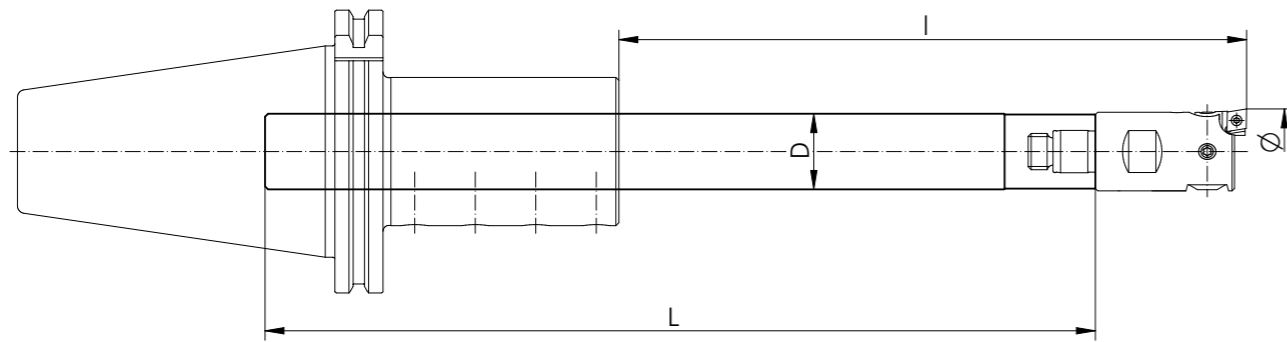

Das LBS-System ist sowohl zum Schlichten als auch zum Schrappen einsetzbar
The LBS-System is suitable for both roughing and finishing

Passende Feinbohrköpfe Seiten 42 und 46, Zweiseneider Schrappköpfe Seite 36
Suitable fine boring heads see pages 42 and 46, double cutter roughing heads see page 36

Ø 29 - 51 mm

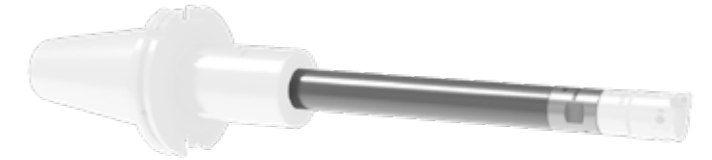

Hartmetall-Bohrstangen
Carbide Boring Bars

Hartmetall-Bohrstangen
Carbide Boring Bars

| Beta | Order Number | Ø-Range | L | I | D | kg | SW | MCM | MCC | Index |
|------|----------------|---------|-----|-----------|----|-----|----|------|-----|-------|
| 25 | H06 25 B25 234 | 29 - 39 | 234 | 167 - 209 | 25 | 1,4 | 22 | ZS25 | B25 | ● |
| 25 | H06 25 B25 276 | 29 - 39 | 276 | 209 - 251 | 25 | 1,7 | 22 | ZS25 | B25 | ● |
| 32 | H06 32 B32 351 | 38 - 51 | 351 | 240 - 320 | 32 | 3,5 | 27 | ZS32 | B32 | ● |

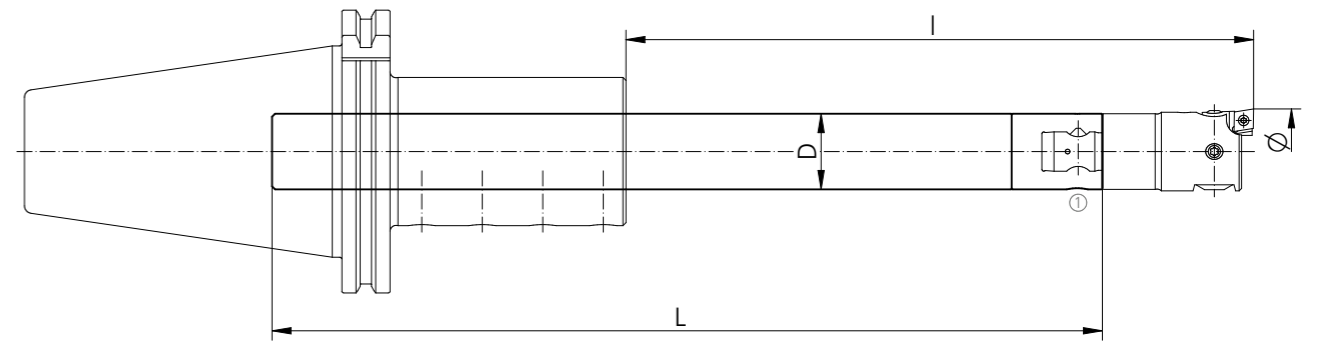

Das LBS-System ist sowohl zum Schlichten als auch zum Schrappen einsetzbar
The LBS-System is suitable for both roughing and finishing

Passende Feinbohrköpfe Seiten 43 und 47, Zweiseneider Schrappköpfe Seite 37
Suitable Fine boring heads see pages 43 and 47, double cutter roughing heads see page 37

SPARE PARTS

| Beta | ① |
|------|-----------|
| 25 | Z00 25 24 |
| 32 | Z00 32 24 |



LBS-Grundaufnahmen

LBS-Tool Holders

Grundaufnahmen MAS-BT

Tool Holders MAS-BT

| Order Number | L | I | D | d | □ | MCC | Index |
|----------------|-----|----|----|------|-------------|--------|-------|
| LT10 41 18 040 | 67 | 40 | 44 | 18,5 | MAS-BT-A/40 | ZS18,5 | ● |
| LT10 43 18 040 | 67 | 40 | 44 | 18,5 | MAS-BT-B/40 | ZS18,5 | ●● |
| LT10 51 18 060 | 98 | 60 | 44 | 18,5 | MAS-BT-A/50 | ZS18,5 | ●● |
| LT10 53 18 060 | 98 | 60 | 44 | 18,5 | MAS-BT-B/50 | ZS18,5 | ●● |
| LT10 41 25 057 | 84 | 57 | 49 | 25 | MAS-BT-A/40 | ZS25 | ●● |
| LT10 43 25 057 | 84 | 57 | 49 | 25 | MAS-BT-B/40 | ZS25 | ●● |
| LT10 51 25 078 | 116 | 78 | 49 | 25 | MAS-BT-A/50 | ZS25 | ●● |
| LT10 53 25 078 | 116 | 78 | 49 | 25 | MAS-BT-B/50 | ZS25 | ●● |
| LT10 51 32 095 | 133 | 95 | 60 | 32 | MAS-BT-A/50 | ZS32 | ●● |
| LT10 53 32 095 | 133 | 95 | 60 | 32 | MAS-BT-B/50 | ZS32 | ●● |

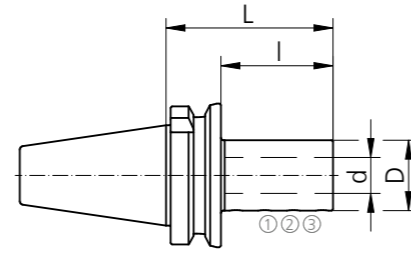

Grundaufnahmen HSK

Tool Holders HSK

| Order Number | L | I | D | d | □ | MCC | Index |
|-----------------|-----|-----|----|------|-----------|--------|-------|
| LH10 63 18 101 | 127 | 85 | 44 | 18,5 | HSK 63-A | ZS18,5 | ● |
| LH10 63 25 117 | 143 | 101 | 49 | 25 | HSK 63-A | ZS25 | ●● |
| LH10 100 18 107 | 152 | 107 | 44 | 18,5 | HSK 100-A | ZS18,5 | ●● |
| LH10 100 25 159 | 204 | 159 | 49 | 25 | HSK 100-A | ZS25 | ●● |
| LH10 100 32 170 | 215 | 170 | 60 | 32 | HSK 100-A | ZS32 | ●● |

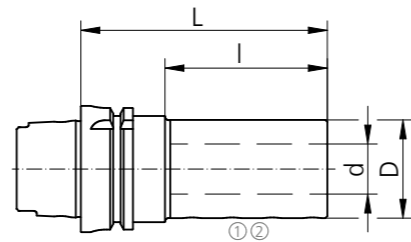

SPARE PARTS

| d | ① | ② | ③ |
|------|-----------|-----------|-----------|
| 18,5 | G00 02 05 | C00 96 10 | |
| 25 | G00 02 05 | | Z00 10 91 |
| 32 | G00 02 06 | C00 96 11 | |

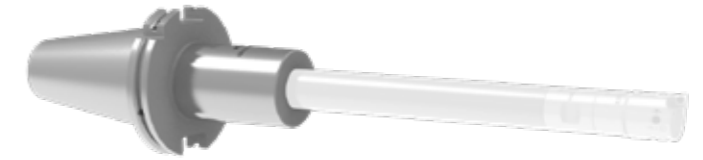

LBS-Grundaufnahmen

LBS-Tool Holders

Grundaufnahmen DIN 69871

Tool Holders DIN 69871

| Order Number | L | I | D | d | □ | MCC | Index |
|----------------|-----|----|----|------|----------------|--------|-------|
| LD10 41 18 042 | 61 | 42 | 44 | 18.5 | DIN 69871-A/40 | ZS18,5 | ● |
| LD10 43 18 042 | 61 | 42 | 44 | 18.5 | DIN 69871-B/40 | ZS18,5 | ●● |
| LD10 50 18 060 | 79 | 60 | 44 | 18.5 | DIN 69871-A/50 | ZS18,5 | ●● |
| LD10 53 18 060 | 79 | 60 | 44 | 18.5 | DIN 69871-B/50 | ZS18,5 | ●● |
| LD10 41 25 059 | 79 | 59 | 49 | 25 | DIN 69871-A/40 | ZS25 | ●● |
| LD10 43 25 059 | 79 | 59 | 49 | 25 | DIN 69871-B/40 | ZS25 | ●● |
| LD10 50 25 078 | 98 | 78 | 49 | 25 | DIN 69871-A/50 | ZS25 | ●● |
| LD10 53 25 078 | 98 | 78 | 49 | 25 | DIN 69871-B/50 | ZS25 | ●● |
| LD10 50 32 095 | 114 | 95 | 60 | 32 | DIN 69871-A/50 | ZS32 | ●● |
| LD10 53 32 095 | 114 | 95 | 60 | 32 | DIN 69871-B/50 | ZS32 | ●● |

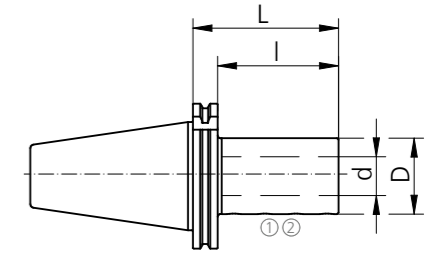



SPARE PARTS

| d | ① | ② |
|------|-----------|-----------|
| 18,5 | G00 02 05 | C00 96 10 |
| 25 | G00 02 05 | C00 96 10 |
| 32 | G00 02 06 | C00 96 11 |

URMA Systems

Modular Components

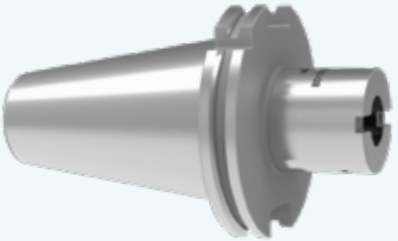
Modulare Komponenten
Modular Components

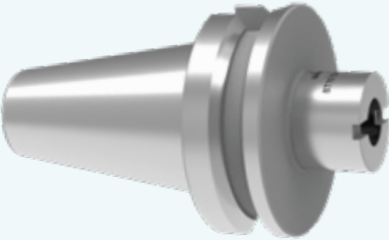
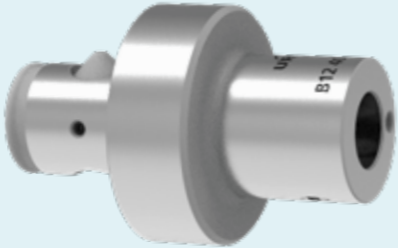
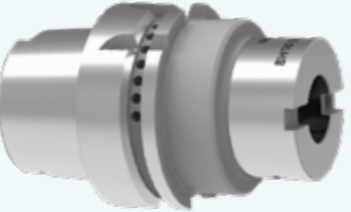
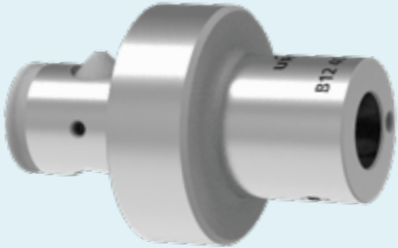
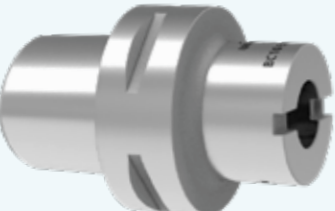
| | | | |
|---|--|-------------------------------|---------|
| Page 104 - 113 | Page 100 - 101 | DigiTec | Page 11 |
|  |  | MicroMax | Page 19 |
|  |  | VersaMax - Type 14 | Page 29 |
| Page 102 - 103 | | VersaMax - Type 25 / Type A25 | Page 39 |
|  |  | IntraMax | Page 51 |
|  | | MegaMax | Page 69 |
| | | SuperMegaMax | Page 81 |



Verlängerungen

Extensions

Verlängerungen Alpha-Alpha

Extensions

| Alpha | Order Number | L | D | kg | SW | MCM | MCC | Index |
|-------|--------------|-----|------|-----|----|------|------|-------|
| 18,5 | 13 18 01 | 25 | 18,5 | 0,1 | 17 | 18,5 | 18,5 | ● |
| 18,5 | 13 18 11 | 35 | 18,5 | 0,1 | 17 | 18,5 | 18,5 | ● |
| 24,5 | 13 24 01 | 30 | 24,5 | 0,1 | 22 | 24,5 | 24,5 | ● |
| 24,5 | 13 24 11 | 45 | 24,5 | 0,2 | 22 | 24,5 | 24,5 | ● |
| 32 | 13 32 01 | 40 | 32 | 0,2 | 27 | 32 | 32 | ● |
| 32 | 13 32 11 | 60 | 32 | 0,3 | 27 | 32 | 32 | ● |
| 42 | 13 42 01 | 50 | 42 | 0,5 | 36 | 42 | 42 | ● |
| 42 | 13 42 11 | 80 | 42 | 0,8 | 36 | 42 | 42 | ● |
| 55 | 13 55 01 | 70 | 55 | 1,2 | 46 | 55 | 55 | ● |
| 55 | 13 55 11 | 105 | 55 | 1,5 | 46 | 55 | 55 | ● |
| 72 | 13 72 01* | 75 | 72 | 2,2 | 60 | 72 | 72 | ● |
| 94 | 13 94 01* | 100 | 94 | 5,1 | 75 | 94 | 94 | ● |

* mit einem Mitnehmerkeil versehen
Supplied with a driving key

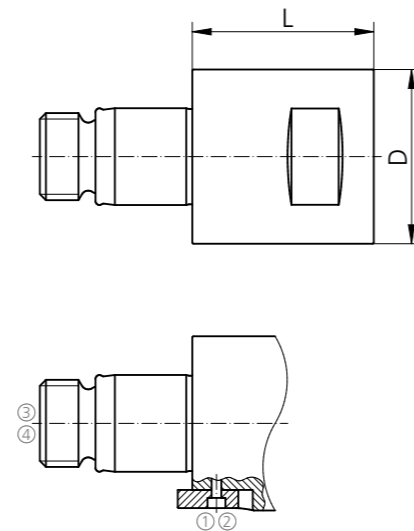

SPARE PARTS

| Alpha | Beta | ① | ② | ③ | ④ |
|-------|------|-----------|-----------|-----------|----------|
| 72 | 80 | Z00 00 72 | C00 22 11 | Z00 14 74 | 53 74 96 |
| 94 | 100 | Z00 00 94 | C00 24 17 | Z00 14 96 | 53 74 96 |

④ Im Lieferumfang nicht enthalten
Not included in the delivery



Verlängerungen

Extensions

Verlängerungen Beta-Beta

Extensions Beta-Beta

| Beta | Order Number | L | D | kg | MCM | MCC | Index |
|------|-----------------|-----|-----|------|------|------|-------|
| 25 | B13 25 25 045 | 45 | 25 | 0,2 | B25 | B25 | ● |
| 25 | B13 25 25 070 | 70 | 25 | 0,3 | B25 | B25 | ● |
| 32 | B13 32 32 035 | 35 | 32 | 0,2 | B32 | B32 | ● |
| 32 | B13 32 32 070 | 70 | 32 | 0,4 | B32 | B32 | ● |
| 40 | B13 40 40 045 | 45 | 42 | 0,4 | B40 | B40 | ● |
| 40 | B13 40 40 070 | 70 | 42 | 0,7 | B40 | B40 | ● |
| 50 | B13 50 50 065 | 65 | 50 | 1,0 | B50 | B50 | ● |
| 50 | B13 50 50 100 | 100 | 50 | 1,5 | B50 | B50 | ● |
| 63 | B13 63 63 060 | 60 | 63 | 1,3 | B63 | B63 | ● |
| 63 | B13 63 63 125 | 125 | 63 | 2,9 | B63 | B63 | ● |
| 80 | B13 80 80 080 | 80 | 80 | 2,9 | B80 | B80 | ● |
| 80 | B13 80 80 160 | 160 | 80 | 6,1 | B80 | B80 | ● |
| 100 | B13 100 100 080 | 80 | 100 | 4,9 | B100 | B100 | ● |
| 100 | B13 100 100 180 | 180 | 100 | 10,9 | B100 | B100 | ● |

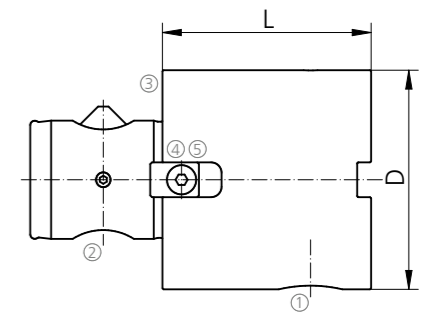

Verlängerungen Alpha-Beta

Extensions Alpha-Beta

| Alpha | Beta | Order Number | L | D | d | kg | SW | MCM | MCC | Index |
|-------|------|----------------|----|-----|------|-----|----|------|------|-------|
| 24,5 | 25 | B13 24 25 030 | 30 | 25 | 24,5 | 0,1 | 22 | 24,5 | B25 | ○ |
| 32 | 32 | B13 32 32 040 | 40 | 32 | 32 | 0,2 | 27 | 32 | B32 | ○ |
| 42 | 40 | B13 42 40 045 | 45 | 42 | 42 | 0,5 | 36 | 42 | B40 | ○ |
| 55 | 63 | B13 55 63 060 | 60 | 63 | 55 | 1,3 | 45 | 55 | B63 | ○ |
| 72 | 80 | B13 72 80 080 | 80 | 80 | 72 | 2,9 | 55 | 72 | B80 | ○ |
| 94 | 100 | B13 94 100 080 | 80 | 100 | 94 | 4,1 | 90 | 94 | B100 | ○ |

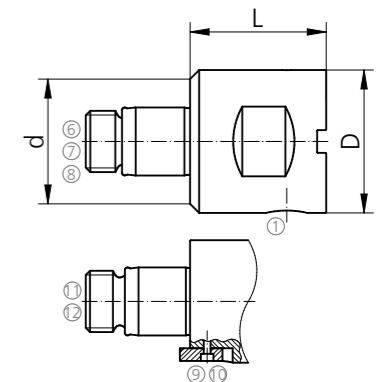

SPARE PARTS

| Alpha | Beta | ① | ② | ③ | ④ | ⑤ | ⑥ | ⑦ | ⑧ | ⑨ | ⑩ | ⑪ | ⑫ |
|-------|------|------------|------------|------------|------------|-----------|-----------|-----------|-----------|-----------|-----------|-----------|----------|
| 24,5 | 25 | Z00 25 24 | Z00 25 21 | Z00 25 23 | | | | | | G00 02 05 | G00 02 02 | Z00 12 24 | |
| 32 | 32 | Z00 32 24 | Z00 32 21 | Z00 32 23 | | | | | | G00 02 06 | G00 02 03 | Z00 16 32 | |
| 42 | 40 | Z00 40 24 | Z00 40 21 | Z00 40 23 | Z00 40 25 | C00 22 58 | G00 02 07 | G00 02 04 | Z00 22 42 | | | | |
| | 50 | Z00 50 24 | Z00 50 21 | Z00 50 23 | Z00 50 25 | C00 22 60 | | | | | | | |
| 55 | 63 | Z00 63 24 | Z00 63 21 | Z00 63 23 | Z00 63 25 | C00 22 05 | G00 02 08 | G00 02 05 | Z00 27 55 | | | | |
| 72 | 80 | Z00 80 24 | Z00 80 21 | Z00 80 23 | Z00 80 25 | C00 22 07 | | | | Z00 00 72 | C00 22 11 | Z00 14 74 | 53 74 96 |
| 94 | 100 | Z00 100 24 | Z00 100 21 | Z00 100 23 | Z00 100 25 | C00 22 71 | | | | Z00 00 94 | C00 24 17 | Z00 14 96 | 53 74 96 |

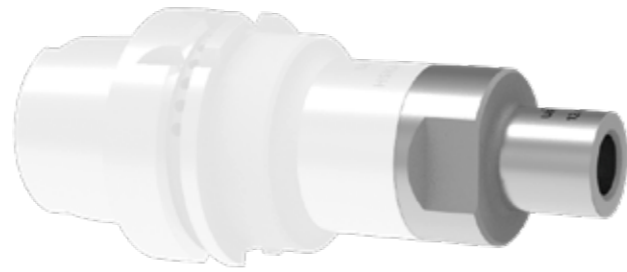

Reduktionen

Reducers

| Alpha | Alpha 1 | Order Number | L | I | D | d | kg | SW | MCM | MCC | Index |
|-------|---------|--------------|-----|----|------|------|-----|----|------|------|-------|
| 24,5 | 18,5 | 12 24 02 | 30 | 15 | 18,5 | 24,5 | 0,1 | 22 | 24,5 | 18,5 | ● |
| 24,5 | 18,5 | 12 24 03 | 55 | 40 | 18,5 | 24,5 | 0,2 | 22 | 24,5 | 18,5 | ● |
| 32 | 18,5 | 12 32 02 | 30 | 15 | 18,5 | 32 | 0,2 | 27 | 32 | 18,5 | ● |
| 32 | 24,5 | 12 32 07 | 40 | 25 | 24,5 | 32 | 0,3 | 27 | 32 | 24,5 | ● |
| 32 | 24,5 | 12 32 08 | 70 | 55 | 24,5 | 32 | 0,3 | 27 | 32 | 24,5 | ● |
| 42 | 18,5 | 12 42 02 | 35 | 15 | 18,5 | 42 | 0,4 | 36 | 42 | 18,5 | ● |
| 42 | 24,5 | 12 42 07 | 45 | 25 | 24,5 | 42 | 0,4 | 36 | 42 | 24,5 | ● |
| 42 | 32 | 12 42 12 | 45 | 25 | 32 | 42 | 0,4 | 36 | 42 | 32 | ● |
| 42 | 32 | 12 42 13 | 85 | 65 | 32 | 42 | 0,7 | 36 | 42 | 32 | ● |
| 55 | 18,5 | 12 55 02 | 40 | 15 | 18,5 | 55 | 0,7 | 46 | 55 | 18,5 | ● |
| 55 | 24,5 | 12 55 07 | 50 | 25 | 24,5 | 55 | 0,7 | 46 | 55 | 24,5 | ● |
| 55 | 32 | 12 55 12 | 50 | 25 | 32 | 55 | 0,7 | 46 | 55 | 32 | ● |
| 55 | 42 | 12 55 17 | 55 | 30 | 42 | 55 | 0,8 | 46 | 55 | 42 | ● |
| 55 | 42 | 12 55 18 | 105 | 80 | 42 | 55 | 1,3 | 46 | 55 | 42 | ● |
| 72 | 18,5 | 12 72 02 | 45 | 15 | 18,5 | 72 | 1,5 | 60 | 72 | 18,5 | ○ |
| 72 | 18,5 | 12 72 03 | 70 | 40 | 18,5 | 72 | 1,5 | 60 | 72 | 18,5 | ○ |
| 72 | 24,5 | 12 72 07 | 55 | 25 | 24,5 | 72 | 1,5 | 60 | 72 | 24,5 | ○ |
| 72 | 32 | 12 72 13 | 95 | 65 | 32 | 72 | 1,8 | 60 | 72 | 32 | ○ |
| 72 | 42 | 12 72 17 | 60 | 30 | 42 | 72 | 1,6 | 60 | 72 | 42 | ● |
| 72 | 55 | 12 72 22 | 60 | 30 | 55 | 72 | 1,7 | 60 | 72 | 55 | ● |
| 94 | 18,5 | 12 94 03 | 75 | 40 | 18,5 | 94 | 2,3 | 75 | 94 | 18,5 | ○ |
| 94 | 24,5 | 12 94 08 | 90 | 55 | 24,5 | 94 | 3,0 | 75 | 94 | 24,5 | ○ |
| 94 | 32 | 12 94 12 | 60 | 25 | 32 | 94 | 3,0 | 75 | 94 | 32 | ○ |
| 94 | 32 | 12 94 13 | 100 | 65 | 32 | 94 | 3,2 | 75 | 94 | 32 | ○ |
| 94 | 55 | 12 94 22 | 60 | 30 | 55 | 94 | 3,1 | 75 | 94 | 55 | ● |
| 94 | 72 | 12 94 27* | 80 | 45 | 72 | 94 | 3,5 | 75 | 94 | 72 | ● |

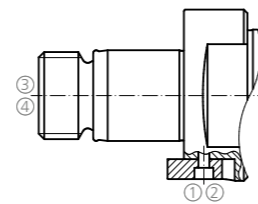
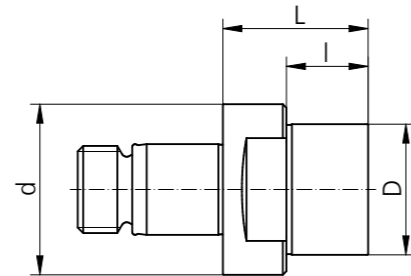

Reduktionen Alpha-Beta

Reducers Alpha-Beta

| Alpha | Beta | Order Number | L | I | D | d | kg | SW | MCM | MCC | Index |
|-------|------|----------------|----|----|----|----|-----|----|-----|-----|-------|
| 32 | 25 | B12 32 25 035 | 35 | 18 | 25 | 32 | 0,3 | 27 | 32 | B25 | ○ |
| 42 | 25 | B12 42 25 045 | 45 | 25 | 25 | 42 | 0,4 | 36 | 42 | B25 | ○ |
| 42 | 32 | B12 42 32 050 | 50 | 30 | 32 | 42 | 0,4 | 36 | 42 | B32 | ○ |
| 55 | 32 | B12 55 32 055 | 55 | 30 | 32 | 55 | 0,7 | 46 | 55 | B32 | ○ |
| 55 | 40 | B12 55 40 060 | 60 | 35 | 42 | 55 | 0,8 | 46 | 55 | B40 | ○ |
| 72 | 40 | B12 72 40 065* | 65 | 35 | 42 | 72 | 1,7 | 60 | 72 | B40 | ○ |
| 72 | 63 | B12 72 63 065* | 65 | 35 | 63 | 72 | 2,0 | 60 | 72 | B63 | ○ |
| 94 | 63 | B12 94 63 070* | 70 | 35 | 63 | 94 | 3,4 | 75 | 94 | B63 | ○ |

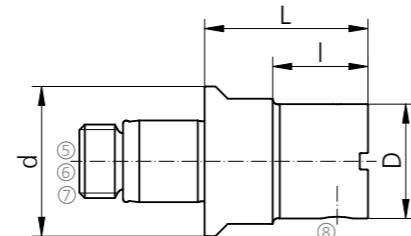

SPARE PARTS

| Alpha | Beta | 1 | 2 | 3 | 4 | 5 | 6 | 7 | 8 |
|-------|------|-----------|-----------|-----------|----------|-----------|-----------|-----------|-----------|
| 25 | | | | | | | | | Z00 25 24 |
| 32 | 32 | | | | | G00 02 06 | G00 02 03 | Z00 16 32 | Z00 25 32 |
| 42 | 40 | | | | | G00 02 07 | G00 02 04 | Z00 22 42 | Z00 25 40 |
| 55 | 63 | | | | | G00 02 05 | Z00 27 55 | Z00 24 63 | |
| 72 | | Z00 00 72 | C00 22 11 | Z00 14 74 | 53 74 96 | | | | |
| 94 | | Z00 00 94 | C00 24 17 | Z00 14 96 | 53 74 96 | | | | |

* mit einem Mitnehmerkeil versehen
supplied with a driving key

④ Im Lieferumfang nicht enthalten
Not included in the delivery



Reduktionen

Reducers

Reduktionen Beta-Beta

Reducers Beta-Beta

| Beta | Beta 1 | Order Number | L | I | D | d | kg | SW | MCM | MCC | Index |
|------|--------|-----------------|----|----|----|-----|-----|----|------|-----|-------|
| 32 | 25 | B12 32 25 040 | 40 | 25 | 25 | 32 | 0,2 | | B32 | B25 | ● |
| 40 | 25 | B12 40 25 040 | 40 | 25 | 25 | 42 | 0,3 | | B40 | B25 | ● |
| 40 | 32 | B12 40 32 045 | 45 | 30 | 32 | 42 | 0,3 | | B40 | B32 | ● |
| 50 | 40 | B12 50 40 050 | 50 | 35 | 42 | 50 | 0,5 | | B50 | B40 | ● |
| 63 | 25 | B12 63 25 045 | 45 | 25 | 25 | 63 | 0,7 | | B63 | B25 | ● |
| 63 | 32 | B12 63 32 050 | 50 | 30 | 32 | 63 | 0,9 | | B63 | B32 | ● |
| 63 | 40 | B12 63 40 055 | 55 | 35 | 42 | 63 | 1,1 | | B63 | B40 | ● |
| 63 | 50 | B12 63 50 060 | 60 | 40 | 50 | 63 | 1,1 | | B63 | B50 | ● |
| 80 | 40 | B12 80 40 060 | 60 | 35 | 42 | 80 | 2,2 | | B80 | B40 | ● |
| 80 | 50 | B12 80 50 060* | 60 | 35 | 50 | 80 | 2,2 | | B80 | B50 | ○ |
| 80 | 63 | B12 80 63 060 | 60 | 35 | 63 | 80 | 2,4 | | B80 | B63 | ● |
| 100 | 40 | B12 100 40 060 | 60 | 35 | 42 | 100 | 2,6 | | B100 | B40 | ○ |
| 100 | 50 | B12 100 50 080* | 80 | 50 | 50 | 100 | 3,5 | | B100 | B50 | ○ |
| 100 | 63 | B12 100 63 060 | 60 | 35 | 63 | 100 | 3,3 | | B100 | B63 | ● |
| 100 | 80 | B12 100 80 075 | 75 | 50 | 80 | 100 | 3,5 | | B100 | B80 | ● |

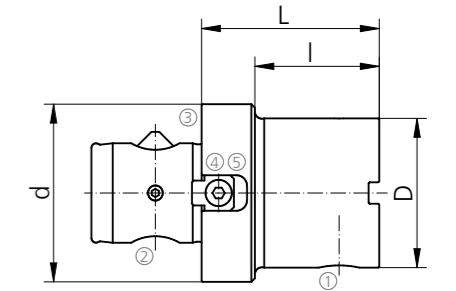

* Ersatzteile auf Anfrage

* Spare parts on request

Reduktionen Beta-Alpha

Reducers Beta-Alpha

| Beta | Alpha | Order Number | L | I | D | d | kg | SW | MCM | MCC | Index |
|------|-------|---------------|----|----|------|----|-----|----|-----|------|-------|
| 25 | 18,5 | B12 25 18 040 | 40 | 25 | 18,5 | 25 | 0,1 | 17 | B25 | 18,5 | ● |
| 32 | 18,5 | B12 32 18 040 | 40 | 25 | 18,5 | 32 | 0,1 | 17 | B32 | 18,5 | ● |
| 40 | 18,5 | B12 40 18 040 | 40 | 25 | 18,5 | 42 | 0,2 | 17 | B40 | 18,5 | ● |
| 50 | 18,5 | B12 50 18 040 | 40 | 15 | 18,5 | 50 | 0,5 | 17 | B50 | 18,5 | ○ |
| 50 | 24,5 | B12 50 24 050 | 50 | 25 | 24,5 | 50 | 0,6 | 22 | B50 | 24,5 | ○ |
| 50 | 32 | B12 50 32 050 | 50 | 25 | 32 | 50 | 0,6 | 27 | B50 | 32 | ○ |
| 60 | 24,5 | B12 63 24 055 | 55 | 25 | 24,5 | 63 | 1,0 | 22 | B63 | 24,5 | ○ |
| 65 | 32 | B12 63 32 055 | 55 | 25 | 32 | 63 | 1,1 | 27 | B63 | 32 | ○ |
| 63 | 42 | B12 63 42 060 | 60 | 30 | 42 | 63 | 1,1 | 36 | B63 | 42 | ○ |

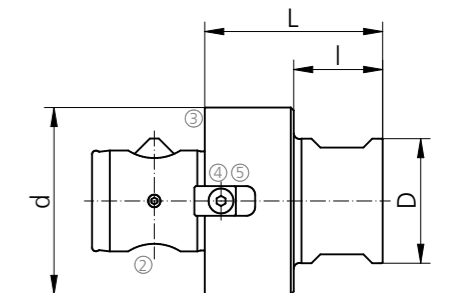

SPARE PARTS

| Beta | 1 | 2 | 3 | 4 | 5 |
|------|------------|------------|------------|------------|-----------|
| 25 | Z00 25 24 | Z00 25 21 | Z00 25 23 | | |
| 32 | Z00 32 24 | Z00 32 21 | Z00 32 23 | | |
| 40 | Z00 40 24 | Z00 40 21 | Z00 40 23 | Z00 40 25 | C00 22 58 |
| 50 | Z00 50 24 | Z00 50 21 | Z00 50 23 | Z00 50 25 | C00 22 60 |
| 63 | Z00 63 24 | Z00 63 21 | Z00 63 23 | Z00 63 25 | C00 22 05 |
| 80 | Z00 80 24 | Z00 80 21 | Z00 80 23 | Z00 80 25 | C00 22 07 |
| 100 | Z00 100 24 | Z00 100 21 | Z00 100 23 | Z00 100 25 | C00 22 71 |



System-Aufnahmen
System Adaptors

Mit axialer Schraubverbindung
With Axial Threaded Connection

DIN 69871-A/D

| Alpha | Order Number | □ | L | I | D | kg | MCC | Index |
|-------|--------------|----|-----|-----|------|-----|------|-------|
| 18,5 | D10 31 02 | 30 | 34 | 15 | 18,5 | 0,4 | 18,5 | ○ |
| 32 | D10 31 12 | 30 | 44 | 25 | 32 | 0,5 | 32 | ○ |
| 42 | D10 31 16 | 30 | 35 | 16 | 42 | 0,4 | 42 | ● |
| 42 | D10 31 17 | 30 | 49 | 30 | 42 | 0,5 | 42 | ○ |
| 18,5 | D10 41 03 | 40 | 75 | 40 | 18,5 | 1,1 | 18,5 | ● |
| 24,5 | D10 41 07 | 40 | 60 | 25 | 24,5 | 1,1 | 24,5 | ● |
| 24,5 | D10 41 08 | 40 | 90 | 55 | 24,5 | 1,2 | 24,5 | ● |
| 32 | D10 41 12 | 40 | 60 | 25 | 32 | 1,1 | 32 | ● |
| 32 | D10 41 13 | 40 | 100 | 65 | 32 | 1,4 | 32 | ● |
| 32 | D10 41 14 | 40 | 100 | 125 | 32 | 1,8 | 32 | ○ |
| 42 | D10 41 16 | 40 | 35 | 16 | 42 | 1,2 | 42 | ● |
| 42 | D10 41 17 | 40 | 65 | 30 | 42 | 1,3 | 42 | ● |
| 55 | D10 41 22 | 40 | 65 | 46 | 55 | 1,2 | 55 | ● |
| 55 | D10 41 23 | 40 | 135 | 100 | 55 | 2,6 | 55 | ○ |
| 72 | D10 41 27 | 40 | 80 | 45 | 72 | 1,8 | 72 | ○ |
| 18,5 | D10 50 03 | 50 | 75 | 40 | 18,5 | 3,2 | 18,5 | ○ |
| 24,5 | D10 50 07 | 50 | 60 | 25 | 24,5 | 3,2 | 24,5 | ● |
| 32 | D10 50 12 | 50 | 60 | 25 | 32 | 3,2 | 32 | ● |
| 42 | D10 50 17 | 50 | 65 | 30 | 42 | 4,0 | 42 | ● |
| 55 | D10 50 22 | 50 | 65 | 30 | 55 | 3,3 | 55 | ● |
| 55 | D10 50 24 | 50 | 240 | 105 | 55 | 6,7 | 55 | ○ |
| 72 | D10 50 27 | 50 | 80 | 61 | 72 | 3,7 | 72 | ● |
| 94 | D10 50 32 | 50 | 85 | 66 | 94 | 4,0 | 94 | ● |

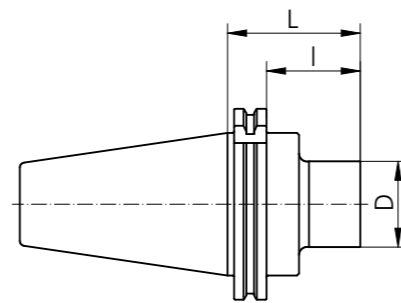

DIN 69871-B

| Alpha | Order Number | □ | L | I | D | kg | MCC | Index |
|-------|--------------|----|----|----|----|-----|-----|-------|
| 42 | H10 43 16 | 40 | 35 | 16 | 42 | 1,2 | 42 | ● |
| 55 | H10 43 22 | 40 | 65 | 46 | 55 | 1,2 | 55 | ● |
| 42 | H10 53 17 | 50 | 65 | 30 | 42 | 4,0 | 42 | ● |
| 55 | H10 53 22 | 50 | 65 | 30 | 55 | 3,3 | 55 | ● |
| 72 | H10 53 27 | 50 | 80 | 61 | 72 | 3,7 | 72 | ● |
| 94 | H10 53 32 | 50 | 85 | 66 | 94 | 4,0 | 94 | ● |

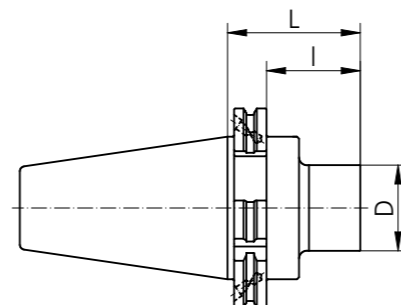

D = 72 mm mit einer Mitnehmernut
 D = 94 mm mit zwei Mitnehmernuten
 D = 72 mm with one driving keyway
 D = 94 mm with two driving keyways

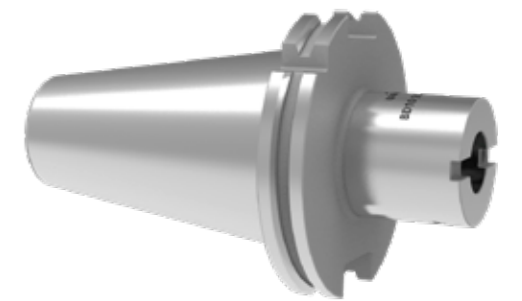
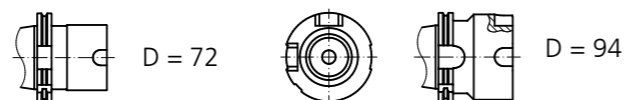

System-Aufnahmen
System Adaptors

Mit Radialspannung
With Side Lock System

DIN 69871-A/D

| Beta | Order Number | □ | L | I | D | kg | MCC | Index |
|------|------------------|----|-----|----|-----|-----|------|-------|
| 25 | BD10 40A 25 050 | 40 | 50 | 31 | 25 | 0,8 | B25 | ● |
| 32 | BD10 40A 32 050 | 40 | 50 | 31 | 32 | 0,9 | B32 | ● |
| 40 | BD10 40A 40 035 | 40 | 35 | 16 | 42 | 0,9 | B40 | ● |
| 40 | BD10 40A 40 050 | 40 | 50 | 31 | 42 | 1,1 | B40 | ● |
| 50 | BD10 40A 50 050 | 40 | 50 | 31 | 50 | 1,2 | B50 | ● |
| 63 | BD10 40A 63 065 | 40 | 65 | 46 | 63 | 1,5 | B63 | ● |
| 25 | BD10 50A 25 060 | 50 | 60 | 41 | 25 | 2,8 | B25 | ● |
| 32 | BD10 50A 32 060 | 50 | 60 | 41 | 32 | 2,9 | B32 | ● |
| 40 | BD10 50A 40 060 | 50 | 60 | 41 | 42 | 3,0 | B40 | ● |
| 50 | BD10 50A 50 060 | 50 | 60 | 41 | 50 | 3,2 | B50 | ● |
| 63 | BD10 50A 63 060 | 50 | 60 | 41 | 63 | 3,3 | B63 | ● |
| 80 | BD10 50A 80 070 | 50 | 70 | 51 | 80 | 4,0 | B80 | ● |
| 100 | BD10 50A 100 115 | 50 | 115 | 96 | 100 | 6,9 | B100 | ● |

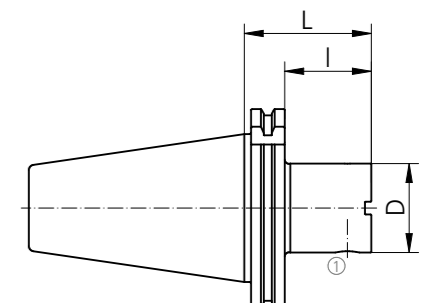

DIN 69871-B

| Beta | Order Number | □ | L | I | D | kg | MCC | Index |
|------|------------------|----|-----|----|-----|-----|------|-------|
| 40 | BD10 40B 40 035 | 40 | 35 | 16 | 42 | 0,9 | B40 | ● |
| 63 | BD10 40B 63 065 | 40 | 65 | 46 | 63 | 1,5 | B63 | ● |
| 63 | BD10 40B 63 090 | 40 | 90 | 55 | 63 | 2,0 | B63 | ○ |
| 40 | BD10 50B 40 060 | 50 | 60 | 41 | 42 | 3,0 | B40 | ● |
| 50 | BD10 50B 50 060 | 50 | 60 | 41 | 50 | 3,2 | B50 | ● |
| 63 | BD10 50B 63 060 | 50 | 60 | 41 | 63 | 3,3 | B63 | ● |
| 100 | BD10 50B 100 115 | 50 | 115 | 96 | 100 | 6,9 | B100 | ● |

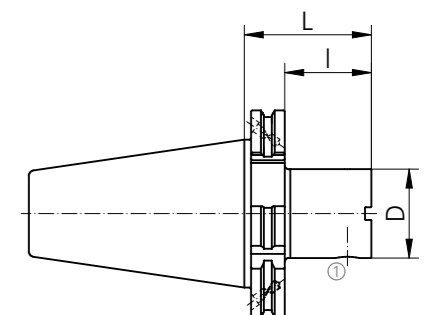

SPARE PARTS

| Beta | ① |
|------|------------|
| 25 | Z00 25 24 |
| 32 | Z00 32 24 |
| 40 | Z00 40 24 |
| 50 | Z00 50 24 |
| 63 | Z00 63 24 |
| 80 | Z00 80 24 |
| 100 | Z00 100 24 |



System-Aufnahmen
System Adaptors

Mit axialer Schraubverbindung
With Axial Threaded Connection

MAS-BT-A

| Alpha | Order Number | ▽ | L | I | D | kg | MCC | Index |
|-------|--------------|----|-----|-----|------|------|------|-------|
| 18,5 | T10 31 02 | 30 | 37 | 15 | 18,5 | 0,4 | 18,5 | ○ |
| 32 | T10 31 12 | 30 | 47 | 25 | 32 | 0,5 | 32 | ○ |
| 42 | T10 31 16 | 30 | 32 | 10 | 42 | 0,8 | 42 | ○ |
| 18,5 | T10 41 03 | 40 | 67 | 40 | 18,5 | 1,0 | 18,5 | ● |
| 18,5 | T10 41 04 | 40 | 102 | 75 | 18,5 | 1,1 | 18,5 | ○ |
| 24,5 | T10 41 07 | 40 | 52 | 25 | 24,5 | 1,0 | 24,5 | ● |
| 32 | T10 41 12 | 40 | 52 | 25 | 32 | 1,0 | 32 | ● |
| 42 | T10 41 16 | 40 | 29 | 2 | 42 | 1,0 | 42 | ● |
| 42 | T10 41 17 | 40 | 57 | 30 | 42 | 1,1 | 42 | ● |
| 42 | T10 41 18 | 40 | 107 | 80 | 42 | 1,7 | 42 | ○ |
| 55 | T10 41 22 | 40 | 57 | 30 | 55 | 1,2 | 55 | ● |
| 55 | T10 41 23 | 40 | 127 | 100 | 55 | 2,5 | 55 | ○ |
| 24,5 | T10 51 09 | 50 | 138 | 100 | 24,5 | 4,0 | 24,5 | ○ |
| 32 | T10 51 13 | 50 | 103 | 65 | 32 | 4,0 | 32 | ● |
| 42 | T10 51 17 | 50 | 68 | 30 | 42 | 3,3 | 42 | ● |
| 42 | T10 51 19 | 50 | 198 | 160 | 42 | 5,2 | 42 | ○ |
| 55 | T10 51 22 | 50 | 68 | 30 | 55 | 3,8 | 55 | ● |
| 55 | T10 51 24 | 50 | 243 | 205 | 55 | 7,1 | 55 | ○ |
| 72 | T10 51 27 | 50 | 83 | 45 | 72 | 4,2 | 72 | ● |
| 72 | T10 51 29 | 50 | 293 | 255 | 72 | 10,8 | 72 | ○ |
| 94 | T10 51 32 | 50 | 88 | 50 | 94 | 4,7 | 94 | ● |

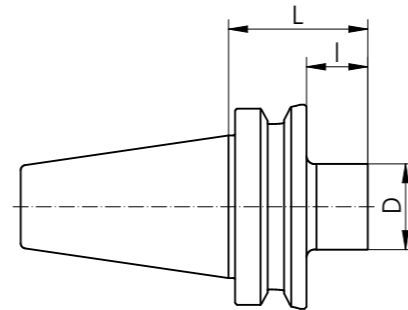

MAS-BT-B

| Alpha | Order Number | ▽ | L | I | D | kg | MCC | Index |
|-------|--------------|----|----|----|------|-----|------|-------|
| 24,5 | T10 43 07 | 40 | 52 | 25 | 24,5 | 1,1 | 24,5 | |
| 32 | T10 43 12 | 40 | 52 | 25 | 32 | 1,1 | 32 | |
| 42 | T10 43 16 | 40 | 29 | 2 | 42 | 0,9 | 42 | |
| 55 | T10 43 22 | 40 | 57 | 30 | 55 | 1,2 | 55 | |

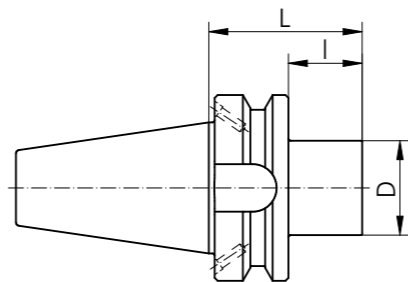

D = 72 mm mit einer Mitnehmernut
D = 94 mm mit zwei Mitnehmernuten
D = 72 mm with one driving keyway
D = 94 mm with two driving keyways

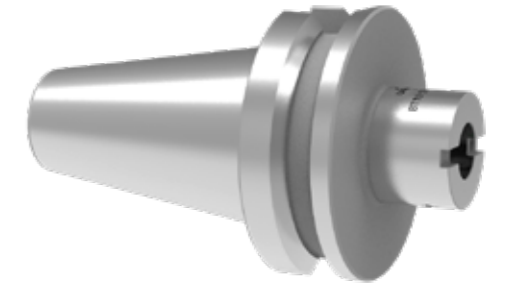
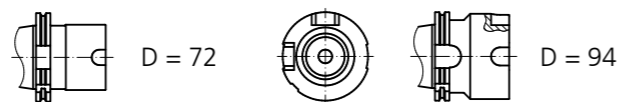

System-Aufnahmen
System Adaptors

Mit Radialspannung
With Side Lock System

MAS-BT-A

| Beta | Order Number | ▽ | L | I | D | kg | MCC | Index |
|------|------------------|----|-----|----|-----|-----|------|-------|
| 25 | BT10 40A 25 060 | 40 | 60 | 33 | 25 | 0,8 | B25 | ● |
| 32 | BT10 40A 32 060 | 40 | 60 | 33 | 32 | 0,9 | B32 | ● |
| 40 | BT10 40A 40 028 | 40 | 28 | 1 | 42 | 0,9 | B40 | ● |
| 40 | BT10 40A 40 060 | 40 | 60 | 33 | 42 | 1,2 | B40 | ● |
| 50 | BT10 40A 50 060 | 40 | 60 | 33 | 50 | 1,3 | B50 | ● |
| 63 | BT10 40A 63 055 | 40 | 55 | 28 | 63 | 1,4 | B63 | ● |
| 32 | BT10 50A 32 070 | 50 | 70 | 32 | 32 | 3,7 | B32 | ● |
| 40 | BT10 50A 40 070 | 50 | 70 | 32 | 42 | 3,9 | B40 | ● |
| 50 | BT10 50A 50 070 | 50 | 70 | 32 | 50 | 4,1 | B50 | ● |
| 63 | BT10 50A 63 080 | 50 | 80 | 42 | 63 | 4,3 | B63 | ● |
| 80 | BT10 50A 80 100 | 50 | 100 | 62 | 80 | 5,5 | B80 | ● |
| 100 | BT10 50A 100 110 | 50 | 110 | 72 | 100 | 7,0 | B100 | ● |

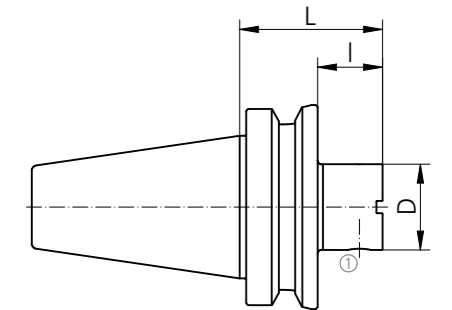

MAS-BT-B

| Beta | Order Number | ▽ | L | I | D | kg | MCC | Index |
|------|------------------|----|-----|----|-----|-----|------|-------|
| 32 | BT10 50B 32 070 | 50 | 70 | 32 | 32 | 3,8 | B32 | ○ |
| 40 | BT10 40B 40 060 | 40 | 60 | 33 | 42 | 1,3 | B40 | ○ |
| 50 | BT10 50B 50 070 | 50 | 70 | 32 | 50 | 4,0 | B50 | ○ |
| 63 | BT10 50B 63 080 | 50 | 80 | 42 | 63 | 4,4 | B63 | ○ |
| 100 | BT10 50B 100 110 | 50 | 110 | 72 | 100 | 6,3 | B100 | ○ |

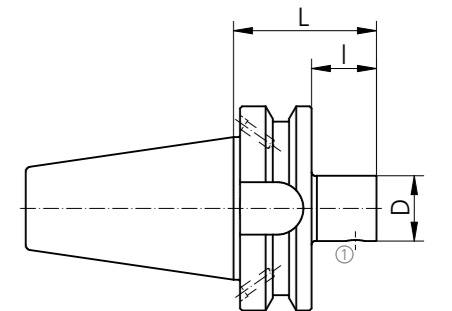

SPARE PARTS

| Beta | Order Number |
|------|--------------|
| 25 | Z00 25 24 |
| 32 | Z00 32 24 |
| 40 | Z00 40 24 |
| 50 | Z00 50 24 |
| 63 | Z00 63 24 |
| 80 | Z00 80 24 |
| 100 | Z00 100 24 |

System-Aufnahmen URMA-FT

System Adaptors URMA-FT

Mit Radialspannung

With Side Lock System

**Für erhöhte Stabilität und grössere Zerspanungsleistung
Analog zu bestehenden Systemen**

For improved rigidity and higher cutting performance
Equivalent to existing systems

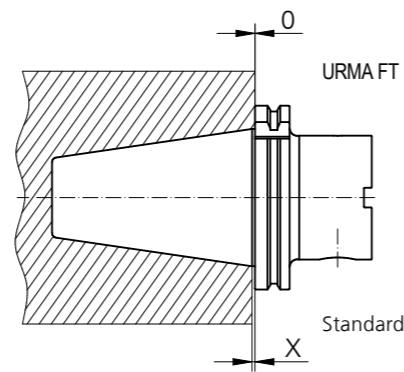

DIN 69871-A

| Beta | Order Number | | L | I | D | kg | MCC | Index |
|------|-------------------|----|-----|----|-----|-----|------|-------|
| 40 | BDP10 50A 40 060 | 50 | 60 | 41 | 42 | 3,0 | B40 | ● |
| 63 | BDP10 50A 63 060 | 50 | 60 | 41 | 63 | 3,3 | B63 | ● |
| 80 | BDP10 50A 80 070 | 50 | 70 | 51 | 80 | 4,0 | B80 | ● |
| 100 | BDP10 50A 100 115 | 50 | 115 | 96 | 100 | 6,9 | B100 | ● |

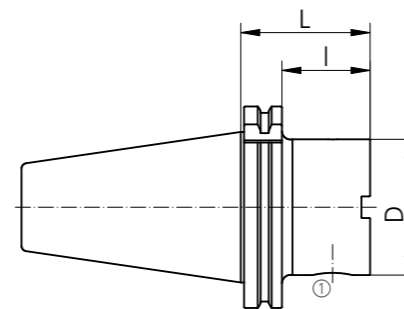

SPARE PARTS

| Beta | |
|------|------------|
| 40 | Z00 40 24 |
| 63 | Z00 63 24 |
| 80 | Z00 80 24 |
| 100 | Z00 100 24 |

System-Aufnahmen URMA-FT

System Adaptors URMA-FT

Mit Radialspannung

With Side Lock System

**Für erhöhte Stabilität und grössere Zerspanungsleistung
Analog zu bestehenden Systemen**

For improved rigidity and higher cutting performance
Equivalent to existing systems

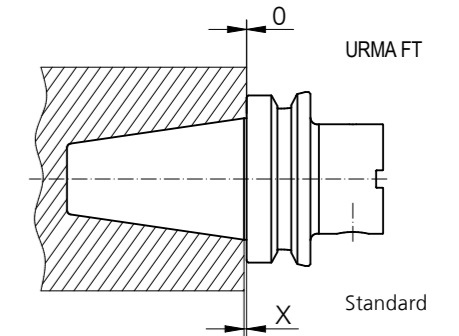

MAS-BT-A

| Beta | Order Number | | L | I | D | kg | MCC | Index |
|------|-------------------|----|-----|----|-----|-----|------|-------|
| 40 | BTP10 40A 40 028 | 40 | 28 | 1 | 42 | 0,9 | B40 | ● |
| 63 | BTP10 40A 63 055 | 40 | 55 | 28 | 63 | 1,5 | B63 | ● |
| 63 | BTP10 50A 63 080 | 50 | 80 | 42 | 63 | 4,3 | B63 | ● |
| 100 | BTP10 50A 100 110 | 50 | 110 | 72 | 100 | 7,0 | B100 | ● |

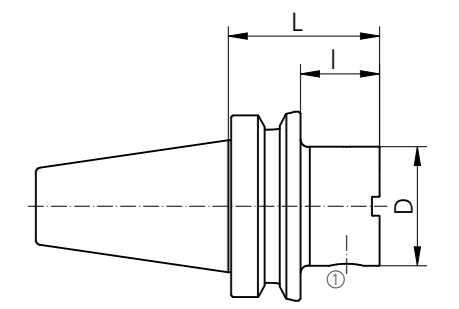

SPARE PARTS

| Beta | |
|------|------------|
| 40 | Z00 40 24 |
| 63 | Z00 63 24 |
| 80 | Z00 80 24 |
| 100 | Z00 100 24 |



System-Aufnahmen
System Adaptors

Mit axialer Schraubverbindung
With Axial Threaded Connection

DIN 69893-A

| Alpha | Order Number | ▽ | L | I | D | kg | MCC | Index |
|-------|-----------------|-----|-----|----|------|-----|------|-------|
| 18,5 | HSKA10 40 02 | 40 | 50 | 15 | 18,5 | 0,3 | 18,5 | ○ |
| 24,5 | HSKA10 40 07 | 40 | 60 | 25 | 24,5 | 0,4 | 24,5 | ○ |
| 32 | HSKA10 40 12 | 40 | 65 | 30 | 32 | 0,4 | 32 | ○ |
| 42 | HSKA10 50 17 | 50 | 72 | 46 | 42 | 0,7 | 42 | ○ |
| 18,5 | HSKA10 63 02* | 63 | 57 | 15 | 18,5 | 1,0 | 18,5 | ● |
| 24,5 | HSKA10 63 07* | 63 | 67 | 25 | 24,5 | 1,0 | 24,5 | ● |
| 32 | HSKA10 63 12* | 63 | 67 | 25 | 32 | 1,1 | 32 | ● |
| 42 | HSKA10 63 17* | 63 | 72 | 30 | 42 | 1,2 | 42 | ● |
| 55 | HSKA10 63 21* | 63 | 82 | 56 | 55 | 1,4 | 55 | ● |
| 72 | HSKA10 63 26 | 63 | 97 | 55 | 72 | 2,2 | 72 | ○ |
| 55 | HSKA10 80 21 | 80 | 82 | 40 | 55 | 2,0 | 55 | ○ |
| 72 | HSKA10 80 26 | 80 | 102 | 60 | 72 | 2,8 | 72 | ○ |
| 94 | HSKA10 80 32 | 80 | 122 | 80 | 94 | 4,5 | 94 | ○ |
| 18,5 | HSKA10 100 03 | 100 | 85 | 40 | 18,5 | 2,8 | 18,5 | ○ |
| 24,5 | HSKA10 100 07 | 100 | 70 | 25 | 24,5 | 2,8 | 24,5 | ○ |
| 24,5 | HSKA10 100 08 | 100 | 100 | 55 | 24,5 | 2,9 | 24,5 | ○ |
| 32 | HSKA10 100 12 | 100 | 70 | 25 | 32 | 2,8 | 32 | ○ |
| 32 | HSKA10 100 13 | 100 | 110 | 65 | 32 | 3,0 | 32 | ○ |
| 42 | HSKA10 100 17* | 100 | 75 | 30 | 42 | 3,0 | 42 | ● |
| 42 | HSKA10 100 18 | 100 | 125 | 80 | 42 | 3,4 | 42 | ○ |
| 55 | HSKA10 100 21* | 100 | 85 | 40 | 55 | 3,3 | 55 | ● |
| 72 | HSKA10 100 26** | 100 | 100 | 55 | 72 | 4,2 | 72 | ● |
| 94 | HSKA10 100 32** | 100 | 125 | 96 | 94 | 6,0 | 94 | ● |

* Kühlmittelrohr ist nicht inbegriffen
Coolant tube is not included

** Spezial Kühlmittelrohr ist inbegriffen
Coolant tube included

D = 72 mm mit einer Mitnehmernut
D = 94 mm mit zwei Mitnehmernuten

D = 72 mm with one driving keyway
D = 94 mm with two driving keyways

SPARE PARTS



| | |
|-----|------------|
| 40 | H00 40 01 |
| 50 | H00 50 01 |
| 63 | H00 63 01 |
| 80 | H00 80 01 |
| 100 | H00 100 01 |

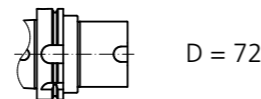
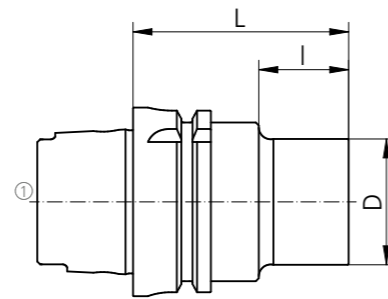

D = 72

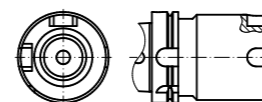

D = 94

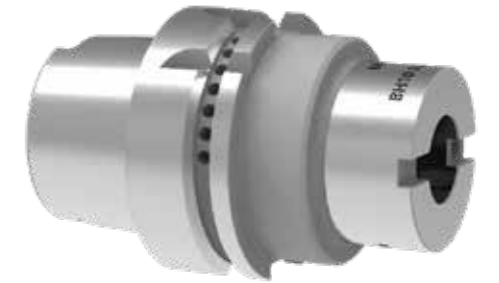

System-Aufnahmen
System Adaptors

Mit Radialspannung
With Side Lock System

DIN 69893-A

| Beta | Order Number | ▽ | L | I | D | kg | MCC | Index |
|------|--------------------|-----|-----|----|-----|-----|------|-------|
| 25 | BH10 50A 25 055 | 50 | 55 | 29 | 25 | 0,5 | B25 | ○ |
| 32 | BH10 50A 32 060 | 50 | 60 | 34 | 32 | 0,6 | B32 | ○ |
| 40 | BH10 50A 40 065 | 50 | 65 | 39 | 42 | 0,7 | B40 | ○ |
| 25 | BH10 63A 25 055* | 63 | 55 | 29 | 25 | 0,9 | B25 | ● |
| 32 | BH10 63A 32 060* | 63 | 60 | 34 | 32 | 1,0 | B32 | ● |
| 40 | BH10 63A 40 065* | 63 | 65 | 23 | 42 | 1,1 | B40 | ● |
| 50 | BH10 63A 50 070* | 63 | 70 | 28 | 50 | 1,5 | B50 | ● |
| 63 | BH10 63A 63 080* | 63 | 80 | 54 | 63 | 1,5 | B63 | ● |
| 40 | BH10 80A 40 065 | 80 | 65 | 23 | 42 | 1,7 | B40 | ○ |
| 63 | BH10 80A 63 080 | 80 | 80 | 38 | 63 | 2,1 | B63 | ○ |
| 80 | BH10 80A 80 090 | 80 | 90 | 48 | 80 | 2,7 | B80 | ○ |
| 100 | BH10 80A 100 100 | 80 | 100 | 58 | 100 | 3,8 | B100 | ○ |
| 32 | BH10 100A 32 060* | 100 | 60 | 31 | 32 | 2,3 | B32 | ● |
| 40 | BH10 100A 40 080* | 100 | 80 | 35 | 42 | 3,1 | B40 | ● |
| 50 | BH10 100A 50 080* | 100 | 80 | 35 | 50 | 3,2 | B50 | ● |
| 63 | BH10 100A 63 080* | 100 | 80 | 35 | 63 | 3,3 | B63 | ● |
| 80 | BH10 100A 80 090* | 100 | 90 | 45 | 80 | 4,0 | B80 | ● |
| 100 | BH10 100A 100 100* | 100 | 100 | 71 | 100 | 5,0 | B100 | ● |

* Kühlmittelrohr ist nicht inbegriffen
Coolant tube is not included

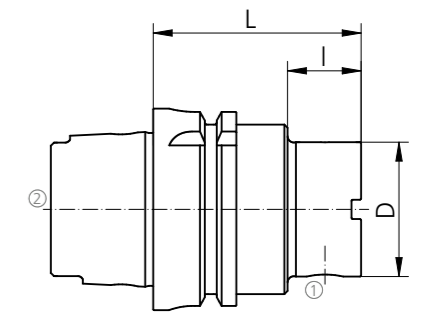

SPARE PARTS



| | | | |
|-----|------------|-----|------------|
| 25 | Z00 25 24 | 80 | H00 50 01 |
| 32 | Z00 32 24 | 63 | H00 63 01 |
| 40 | Z00 40 24 | 80 | H00 80 01 |
| 50 | Z00 50 24 | 100 | H00 100 01 |
| 63 | Z00 63 24 | | |
| 80 | Z00 80 24 | | |
| 100 | Z00 100 24 | | |

System-Aufnahmen
System Adaptors

Mit axialer Schraubverbindung
With Axial Threaded Connection

ISO 26623 PSC

| Alpha | Order Number | □ | L | I | D | kg | MCC | Index |
|-------|----------------|--------|----|----|----|-----|-----|-------|
| 42 | AC10 63 17 055 | Size 6 | 55 | 30 | 42 | 1.0 | 42 | ● |
| 55 | AC10 63 21 060 | Size 6 | 60 | 35 | 55 | 1.3 | 55 | ● |

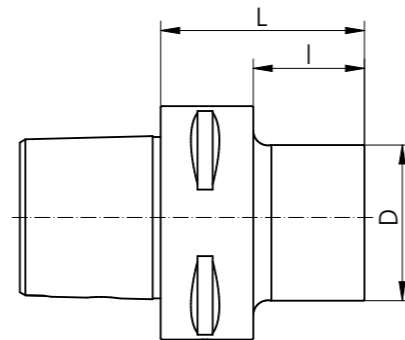

ISO DIN 2080

| Alpha | Order Number | □ | L | I | D | kg | MCC | Index |
|-------|--------------|----|------|----|----|-----|-----|-------|
| 42 | 10 40 16 | 40 | 13,6 | 2 | 42 | 0,9 | 42 | ○ |
| 42 | 10 40 17 | 40 | 41,6 | 30 | 42 | 1,0 | 42 | ○ |
| 55 | 10 40 22 | 40 | 41,6 | 30 | 55 | 1,0 | 55 | ○ |
| 42 | 10 50 17 | 50 | 45,2 | 30 | 42 | 2,8 | 42 | ○ |
| 55 | 10 50 22 | 50 | 45,2 | 30 | 55 | 2,8 | 55 | ○ |
| 72 | 10 50 27 | 50 | 60,2 | 45 | 72 | 3,2 | 72 | ○ |
| 94 | 10 50 32 | 50 | 65,2 | 50 | 94 | 3,5 | 94 | ○ |

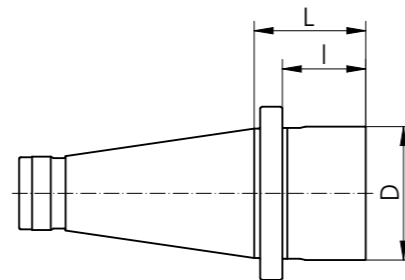

System-Aufnahmen
System Adaptors

Mit Radialspannung
With Side Lock System

ISO 26623-1-PSC

| Beta | Order Number | □ | L | I | D | kg | MCC | Index |
|------|----------------|--------|----|----|----|-----|-----|-------|
| 40 | BC10 63 40 055 | Size 6 | 55 | 30 | 42 | 1.0 | B40 | ● |
| 50 | BC10 63 50 060 | Size 6 | 60 | 35 | 50 | 1.2 | B50 | ● |
| 63 | BC10 63 63 065 | Size 6 | 65 | - | 63 | 1.5 | B63 | ● |

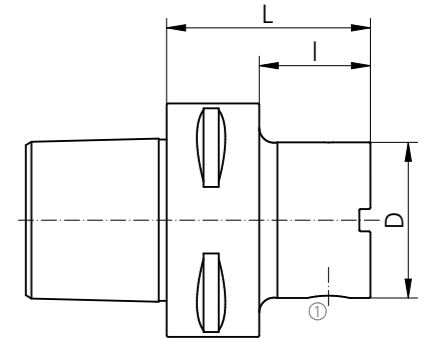

ISO DIN 2080

| Beta | Order Number | □ | L | I | D | kg | MCC | Index |
|------|-----------------|----|-----|----|-----|-----|------|-------|
| 40 | BI10 40 40 035 | 40 | 35 | 23 | 42 | 0,7 | B40 | ○ |
| 40 | BI10 40 40 050 | 40 | 50 | 38 | 42 | 1,1 | B40 | ○ |
| 63 | BI10 40 63 070 | 40 | 70 | 58 | 63 | 1,8 | B63 | ○ |
| 40 | BI10 50 40 060 | 50 | 60 | 45 | 42 | 3,0 | B40 | ○ |
| 63 | BI10 50 63 060 | 50 | 60 | 45 | 63 | 3,5 | B63 | ○ |
| 100 | BI10 50 100 100 | 50 | 100 | 85 | 100 | 6,8 | B100 | ○ |

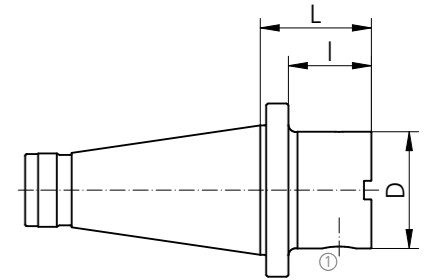

SPARE PARTS

| Beta | ① | |
|------|------------|--|
| 40 | Z00 40 24 | |
| 50 | Z00 50 24 | |
| 63 | Z00 63 24 | |
| 100 | Z00 100 24 | |

URMA Systems

Adaptor Toolholders

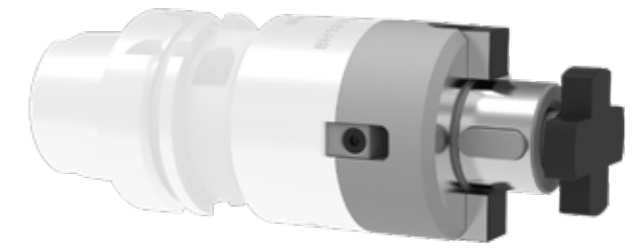

Aufsteckfräsdorne
Shell Mill Adaptors

Aufsteckfräsdorne
Shell End Mill Adaptors

| Beta | Order Number | L | I | D | d | kg | MCM | Index |
|------|---------------|----|----|----|----|-----|-----|-------|
| 63 | B44 63 13 030 | 30 | 12 | 13 | 63 | 0,8 | B63 | ○ |
| | B44 63 16 030 | 30 | 17 | 16 | 63 | 0,8 | B63 | ○ |
| | B44 63 22 030 | 30 | 19 | 22 | 63 | 0,9 | B63 | ○ |
| | B44 63 27 030 | 30 | 21 | 27 | 63 | 1 | B63 | ○ |
| | B44 63 32 030 | 30 | 24 | 32 | 63 | 1,1 | B63 | ○ |
| | B44 63 40 030 | 30 | 27 | 40 | 63 | 1,3 | B63 | ○ |

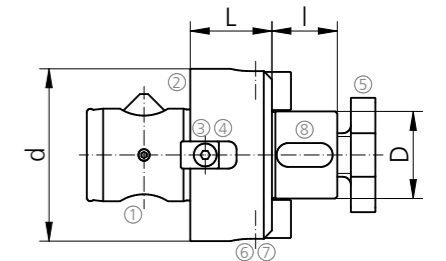

SPARE PARTS

| D | ① | ② | ③ | ④ | ⑤ | ⑥ | ⑦ | ⑧ |
|----|-----------|-----------|-----------|-----------|----------|---------------|-----------|-----------|
| | | | | | | | | |
| | Z00 63 21 | Z00 63 23 | Z00 63 25 | C00 22 05 | | | | |
| 13 | | | | | 52 01 13 | Z00 B44 16 01 | C00 22 30 | |
| 16 | | | | | 52 01 16 | Z00 B44 16 01 | C00 22 30 | F00 04 13 |
| 22 | | | | | 52 01 22 | Z00 B44 22 01 | C00 22 31 | F00 04 14 |
| 27 | | | | | 52 01 27 | Z00 B44 27 01 | C00 22 05 | F00 04 15 |
| 32 | | | | | 52 01 32 | Z00 B44 32 01 | C00 22 71 | F00 04 16 |
| 40 | | | | | 52 01 40 | Z00 B44 40 01 | C00 22 71 | F00 04 17 |



Weldon-Aufnahmen DIN 1835 B

Weldon Adaptors DIN 1835 B

Weldon-Aufnahmen

Weldon Adaptors

| Beta | Order Number | L | I | D | d ₁ | d ₂ | kg | MCM | Index |
|------|---------------|----|----|----|----------------|----------------|-----|-----|-------|
| 40 | B55 40 06 045 | 45 | 30 | 6 | 42 | 25 | 0,3 | B40 | ○ |
| 40 | B55 40 08 045 | 45 | 30 | 8 | 42 | 28 | 0,3 | B40 | ○ |
| 40 | B55 40 10 055 | 55 | 40 | 10 | 42 | 35 | 0,4 | B40 | ○ |
| 40 | B55 40 12 065 | 65 | 65 | 12 | 42 | 42 | 0,6 | B40 | ○ |
| 63 | B55 63 06 050 | 50 | 25 | 6 | 63 | 25 | 0,9 | B63 | ○ |
| 63 | B55 63 08 050 | 50 | 25 | 8 | 63 | 28 | 0,9 | B63 | ○ |
| 63 | B55 63 10 055 | 55 | 30 | 10 | 63 | 35 | 1 | B63 | ○ |
| 63 | B55 63 12 065 | 65 | 40 | 12 | 63 | 42 | 1,1 | B63 | ○ |
| 63 | B55 63 14 065 | 65 | 40 | 14 | 63 | 45 | 1,2 | B63 | ○ |
| 63 | B55 63 16 065 | 65 | 40 | 16 | 63 | 48 | 1,2 | B63 | ○ |
| 63 | B55 63 18 065 | 65 | 40 | 18 | 63 | 50 | 1,3 | B63 | ○ |
| 63 | B55 63 20 065 | 65 | 40 | 20 | 63 | 52 | 1,3 | B63 | ○ |
| 63 | B55 63 25 075 | 75 | 75 | 25 | 63 | 65 | 1,8 | B63 | ○ |

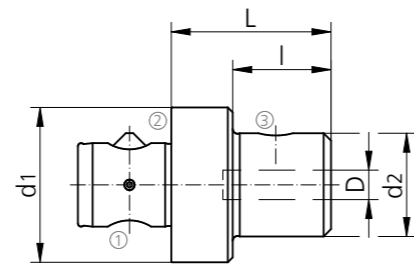

SPARE PARTS

| Beta | D | ① | ② | ③ |
|------|----|-----------|-----------|-----------|
| 40 | | Z00 40 21 | Z00 40 23 | |
| 63 | | Z00 63 21 | Z00 63 23 | |
| | 6 | | | Z00 55 06 |
| | 8 | | | Z00 55 08 |
| | 10 | | | Z00 55 10 |
| | 12 | | | Z00 55 12 |
| | 14 | | | Z00 55 14 |
| | 16 | | | Z00 55 16 |
| | 18 | | | Z00 55 18 |
| | 20 | | | Z00 55 20 |
| | 25 | | | Z00 55 25 |



Spannzangenfutter

Collet Adaptors

Spannzangenfutter

Collet Adaptors

| Beta | Order Number | L | D | d | kg | ER/ESX | MCM | Index |
|------|---------------|----|----|----|-----|--------|-----|-------|
| 40 | B60 40 25 065 | 65 | 42 | 42 | 0,4 | 25 | B40 | ○ |
| 63 | B60 63 32 065 | 65 | 63 | 50 | 1 | 32 | B63 | ○ |

④ Im Lieferumfang nicht enthalten
Not included in the delivery

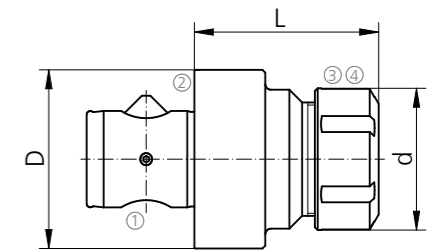

Spannzangensätze

Collet Sets

| Order Number | L | D | d | ER/ESX | MCM | Index |
|--------------|----|--------|----|--------|------|-------|
| 62 25 00 | 34 | 1-15 | 26 | 25 | ER25 | ○ |
| 62 32 00 | 40 | 2,0-20 | 33 | 32 | ER32 | ○ |

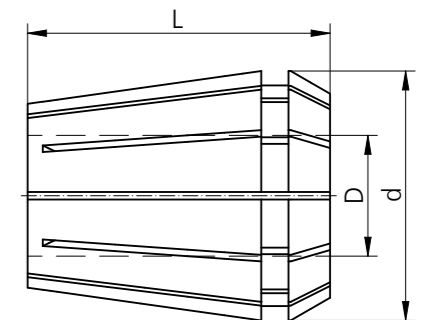

Einzelne Spannzangen

Single Collets

| Order Number | L | D | d | ER/ESX | MCM | Index |
|------------------------|----|--------|----|--------|------|-------|
| 62 25 dd ¹⁾ | 34 | 1-17 | 26 | 25 | ER25 | ○ |
| 62 32 dd ¹⁾ | 40 | 2,0-20 | 33 | 32 | ER32 | ○ |

¹⁾ gewünschten Durchmesser angeben
Indicate required diameter

SPARE PARTS

| Beta | ① | ② | ③ | ④ |
|------|-----------|-----------|-----------|----------|
| 40 | Z00 40 21 | Z00 40 23 | H00 05 05 | 00 05 05 |
| 63 | Z00 63 21 | Z00 63 23 | H00 05 03 | 00 05 02 |

URMA Systems

Special Tools

Sonderwerkzeuge
Special Tools

Erhältlich auf Anfrage
Available on Request

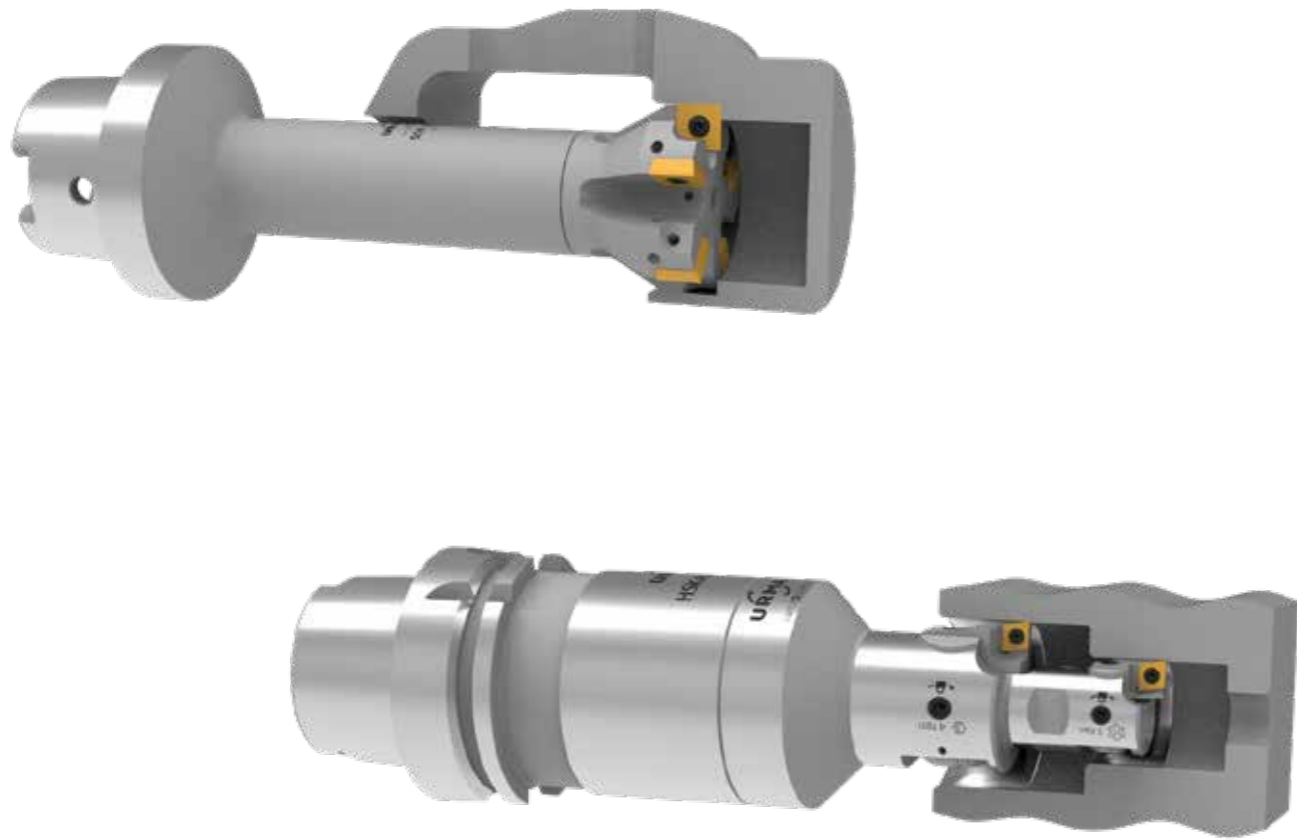

Sonderwerkzeuge
Special Tools

Erhältlich auf Anfrage
Available on Request

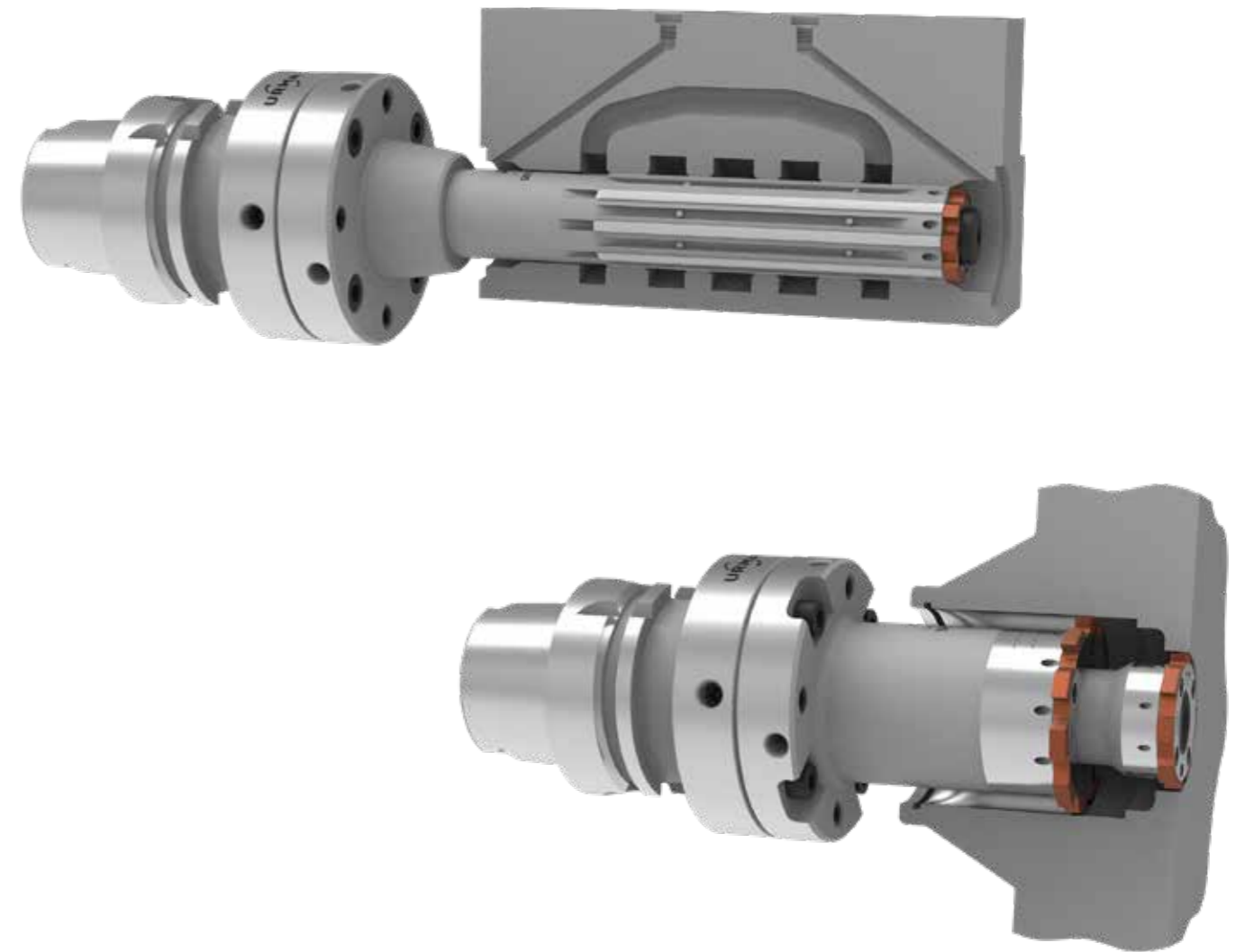

URMA Systems Machining Study

Bearbeitungsstudie

Machining study

| | | |
|---|--|---|
| Absender * Sender | | Number |
| Firma Company | | URMA Vertretung URMA Distributor |
| Adresse Address | | Sachbearbeiter Contact |
| | | Abteilung Department |
| Telefon Telephone | Fax Fax | E-Mail E-Mail |
| Maschine Machine-Tool | | |
| Typ und Hersteller Machine Type | | Leistung (kW) Drive Power (kW) |
| Horizontal * Horizontal <input type="checkbox"/> | Vertikal * Vertical <input type="checkbox"/> | Werkzeug rotierend * Tool rotating <input type="checkbox"/> |
| Spindelaufnahme * Spindle Holder | | Stabilität Stability |
| Einschränkungen aufgrund Restrictions Due to | | |
| Maschine Lubricant | | |
| Öl * Oil <input type="checkbox"/> | MMS * 1) MLS 1) <input type="checkbox"/> | Emulsion * Emulsion <input type="checkbox"/> |
| Innere Kühlmittelzufuhr * Intern. Coolant Supply <input type="checkbox"/> | | Mischungsverhältnis Ratio of Mixture |
| | | Kühlmitteldruck (bar)* Coolant Pressure (Bar) |
| Werkstück Workpiece | | |
| Bezeichnung Designation | Zeichnungsnummer Drawing Number | Werkstoffnummer * Material Number |
| Normbezeichnung * Specification | Behandlungszustand * Treatment Condition | Festigkeit * Strength |
| Anzahl Bohrungen pro Jahr * Number of Bores per Year | Losgrösse Batch Size | |
| Bearbeitungsanforderungen Machining Requirements | | |
| Bohrungs-Ø * Bore ø | Bohrungslänge * Bore Length | Vorbearbeitungs-Ø * Pre-Machined ø |
| Toleranz * Tolerance | Werkzeuglänge (xs) Gage Length (xs) | Vorbearbeitungsart * Method of Pre-Machining |
| Zusätzliche Toleranzanforderungen Additional Tolerance Requirements | Sacklochbohrung * Blind Hole <input type="checkbox"/> | Vorgabezeit Target Time |
| Oberflächengüte (µm) * Surface Quality (µm) | Schnittunterbrechung * Cutting Interruption <input type="checkbox"/> | Vorgabemenge Target Quantity |
| R _a <input type="checkbox"/> R _z <input type="checkbox"/> R _t <input type="checkbox"/> | Taktzeitbindung Cycle Time <input type="checkbox"/> | |
| Datum * Date | Visum * Visa | Beilage: Ihre Bearbeitungsskizze * Attachement: Your Application Sketch |

* **Pflichtfelder**
Mandatory fields

1) **Minder Mengen Schmierung**
Minimal lubrication system (mist coolant)

Fax +41 62 889 20 28
customerservice@urma.ch

URMA Systems
Manuals

Zusammenbau der Systeme Alpha-Modul

Assembly of Systems Alpha-Modul

- | | |
|--|---|
| <ol style="list-style-type: none"> 1. Sicherungsschraube mit kleinem Sechskant zurückdrehen (links) 2. Gewindezapfen mit grossem Sechskant bis zum Anschlag einschrauben (links) 3. Zweischniderkopf und Aufnahme zusammenschrauben, anschliessend zurückdrehen bis Mitnehmerkeil und Nut übereinander stimmen 4. Gewindezapfen mit dem grossen Sechskant durch Linksdrehung in die Aufnahme eindrehen, dann Sicherungsschraube mit dem kleinen Sechskant durch Rechtsdrehung anziehen | <ol style="list-style-type: none"> 1. Loosen locking screw with small hexagonal key (turn counter clock wise) 2. Screw threaded plug with large hexagonal key (clockwise) down to the bottom 3. Screw double cutter head and adaptor together until the slot and key align 4. Screw threaded plug into the adaptor with the large hexagonal key by turning counter clock wise. Tighten the locking screw with the small hexagonal key by turning clock wise |
|--|---|

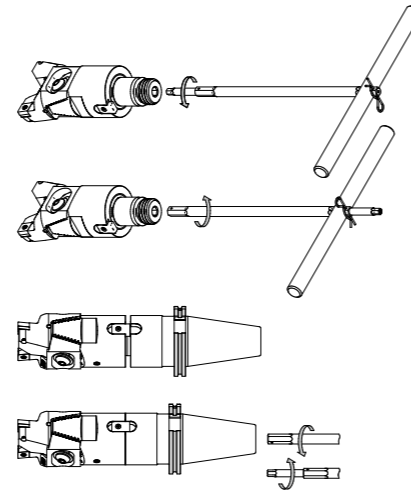

Zusammenbau von Beta-Modul Komponenten

Assembly of Beta-Modul Components

- | | |
|---|--|
| <ol style="list-style-type: none"> 1. Vor dem Zusammenbau überprüfen, ob der Pendelbolzen richtig montiert ist (Senkung muss zur Schraube zeigen) 2. Falls Standard-ABS-Aufnahmen verwendet werden sollen, muss der Keil um 180° gedreht werden (gilt ab Systemgrösse 40) | <ol style="list-style-type: none"> 1. Before assembling, check that the floating bolt has been correctly mounted (indentation must point towards the screw) 2. If standard adaptors are being used, the keyway must be turned through 180° (valid from system size 40) |
|---|--|

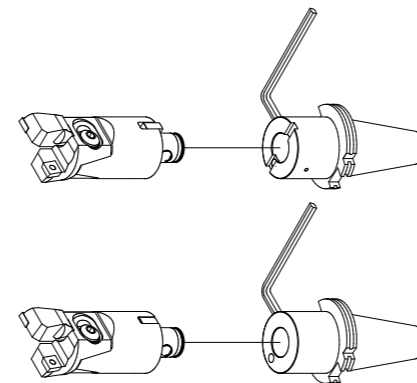

Schneidkanten-Orientierung Feinbohrköpfe

Cutting Edge Orientation of Fine Boring Heads

Ø 0.2 - 153 mm

MicroMax, VersaMax - Type 25/A25

- | | |
|--|---|
| <ol style="list-style-type: none"> 1. Sicherungsschraube lösen - mit dem Schlüssel den Gewindezapfen ganz einschrauben 2. Den Bohrkopf bis zum Anschlag an die Aufnahme einschrauben - Korrekturwinkel bestimmen 3. Mit dem Schlüssel den Gewindezapfen um den 1,5-fachen Betrag des Korrekturwinkels (Alpha) herausdrehen, dann Sicherungsschraube wieder anziehen. 4. Die Schneidkante ist jetzt in Bezug auf die Aufnahme orientiert. | <ol style="list-style-type: none"> 1. Loosening the locking screw, screw the threaded plug in completely with the spanner 2. Screw in the boring head until both faces boring head and adaptor are in contact - define the correction angle (Alpha) 3. Unscrew the threaded plug with the spanner by about 1,5 times the correction angle (Alpha). Re-tighten the locking screw 4. The cutting edge is now orientated on the stop-position of the adaptor |
|--|---|

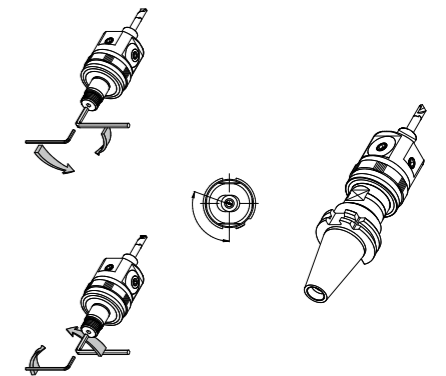

Auswuchten Feinbohrkopf

Balancing the Fine Boring Head

Ø 0.2 - 40 mm

MicroMax

- | | |
|--|--|
| <ol style="list-style-type: none"> 1. Sicherungsschraube A am Ausgleichsring lösen 2. Die beiden Skalen entsprechend dem Bohrungsdurchmesser in Übereinstimmung bringen. Skalierung B für Stahlbohrstangen und Skalierung C für Hartmetall-Bohrstangen. 3. Sicherungsschraube A wieder anziehen 4. Der Kopf ist jetzt für diesen Durchmesser und diese Bohrstange automatisch ausgewuchtet | <ol style="list-style-type: none"> 1. Loosen the locking screw A on the balance ring 2. Align the two scales to set the bore diameter. Scale B corresponds with steel boring bars, scale C with carbide boring bars. 3. Re-tighten the locking screw 4. The boring head is now automatically balanced for the required boring diameter |
|--|--|

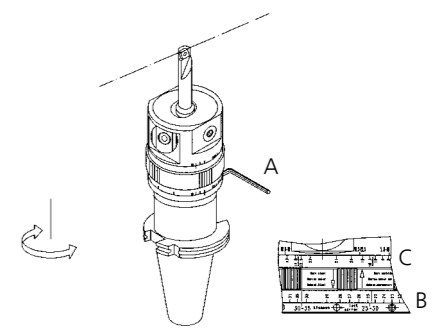

Auswuchten Feinbohrkopf

Balancing the Fine Boring Head

VersaMax - Type A25

Beispiel \varnothing 53 mm

Zum Auswuchten des A25 nur die Skalerringe auf den gewünschten Durchmesser drehen und blockieren

Example \varnothing 53 mm

To balance the A25, simply position the graduated rings to the required diameter value and lock

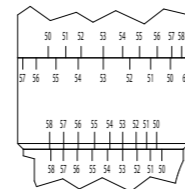

Voreinstellen Feinbohrköpfe

Pre-Setting Fine Boring Heads

MicroMax, VersaMax - Type 25/A25

- | | |
|--|--|
| 1. Blockierschraube A lösen | 1. Loosen locking screw A |
| 2. Ausdrehdurchmesser an der Mikrometerschraube B einstellen | 2. Set the boring diameter at the micrometer screw B |
| 3. Blockierschraube wieder anziehen | 3. Re-tighten the locking screw |

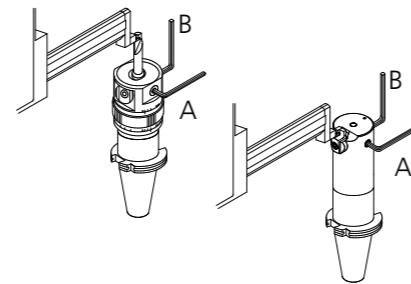

\varnothing 20 - 67 mm

\varnothing 0.2 - 153 mm

Zusammenbau von System IntraMax

Assembly of System IntraMax

IntraMax

- | | |
|--|---|
| 1. Durchmesserkonsole (falls nötig) mit vier Schrauben A auf Aufnahme oder Zwischenkonsole montieren | 1. Mount the diameter adaptor (if need) onto the adaptor or intermediate adaptor with four screws A |
| 2. Schrupp- oder Schlichtplattenhalter mit je zwei Schrauben B montieren (im Normalfall werden zwei Köpfe gleichzeitig eingesetzt) | 2. Mount the roughing or finishing insert holders with two screws B each (normally, two heads are mounted at the same time) |
| 3. Über grobskalieren an Kopf und Konsole Plattenhalter ausrichten | 3. Align the insert holders using the coarse graduations on the head and the adaptor |
| 4. Für die Aussenbearbeitung muss die Zwischenplatte montiert werden | 4. For external machining, the intermediate adaptor must be mounted, C |
| 5. Danach die Schrupp- oder Schlichtplattenhalter mit je zwei Schrauben C montieren | 5. Then mount the roughing or finishing insert holders with two screws C |

\varnothing 49 - 297 mm

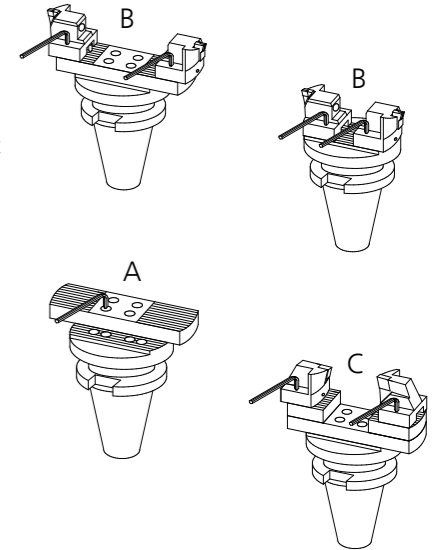

Zusammenbau von System

Assembly of System

MegaMax

- | | |
|---|--|
| <ol style="list-style-type: none"> 1. Durchmesserkonsole (falls nötig) mit vier Schrauben A auf Aufnahme oder Zwischenkonsole montieren 2. Schrupp- oder Schlichtplattenhalter quer zur Verzahnung B einfahren und dann drehen. Bei den Durchmesserkonsolen 150-250 mm müssen dazu die Klemmschrauben C vollständig herausgeschraubt und nach der Montage der Köpfe wieder montiert werden. (Kegelbohrung an Klemmbolzen D beachten). 3. Über grobskalieren an Kopf und Konsole Plattenhalter ausrichten | <ol style="list-style-type: none"> 1. The diameter extender is fastened to the intermediate adaptor with four bolts A 2. Roughing insert holders and fine boring heads are slid laterally across the line of the serration and then rotated B. With diameter extenders \varnothing 150-250 mm it is also necessary to fully unscrew the clamping screws C and refit them after mounting the heads (note taper bore on clamping bolt D). 3. Align the insert holders using the coarse graduations on the head and the adaptor |
|---|--|

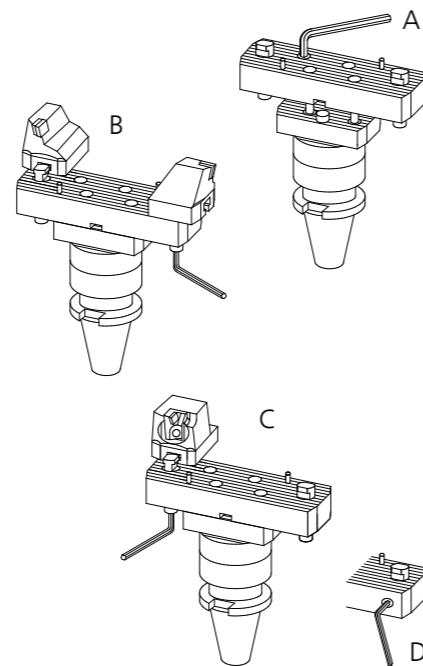

\varnothing 150 - 805 mm

Voreinstellen System

Pre-Setting the System

IntraMax, MegaMax, SuperMegaMax

- | | |
|--|---|
| <ol style="list-style-type: none"> 1. Ausdrehdurchmesser auf dem Voreinstellplatz mittels Skalenschraube A respektive Justierschraube D einstellen 2. Skalenschraubenblockierung E anziehen 3. Wenn gleichzeitig zwei Feinbohrköpfe eingesetzt werden, Feinbohrreinsatz mit Schlüssel C lösen, die Schneide mit Schlüssel B einstellen und mit Schlüssel C erneut klemmen | <ol style="list-style-type: none"> 1. Set the boring diameter to the pre-set position using setting dial A or adjusting screw D respectively 2. Tighten the setting dial locking device E 3. If two fine boring heads are to be used simultaneously, loosen the fine boring insert using key C, set the blade with key B, and reclamp with the key C |
|--|---|

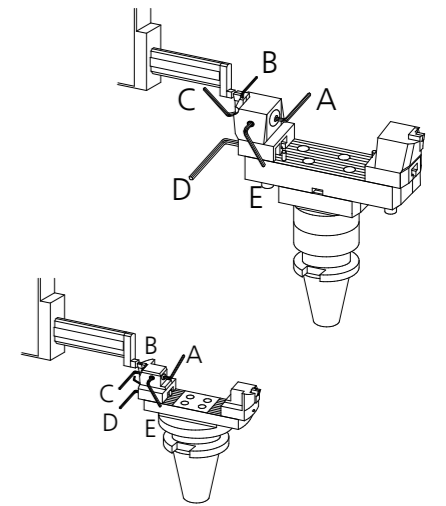

\varnothing 49 - 2'400 mm

Voreinstellen Zweischnider

Setting the Bore Diameter on a Double Cutter

VersaMax - Type 14

- | | |
|--|--|
| <ol style="list-style-type: none"> 1. Klemmschraube A, mit montierter Spannscheibe, vorerst nur leicht anziehen 2. Mit Justierschraube B die Schneide auf genauen Durchmesser einstellen 3. Klemmschraube A fest anziehen | <ol style="list-style-type: none"> 1. Gently tighten clamping screws A (spring washer must be fitted) 2. Set the cutter to the exact diameter with the adjusting screw B 3. Firmly tighten clamping screw A |
|--|--|

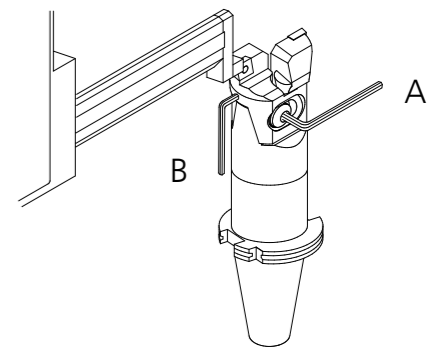

\varnothing 19.5 - 153 mm

URMA Systems
WinTool

WinTool

E-Werkzeugverwaltung mit URMA Katalog E-Tool Management with URMA Catalogue

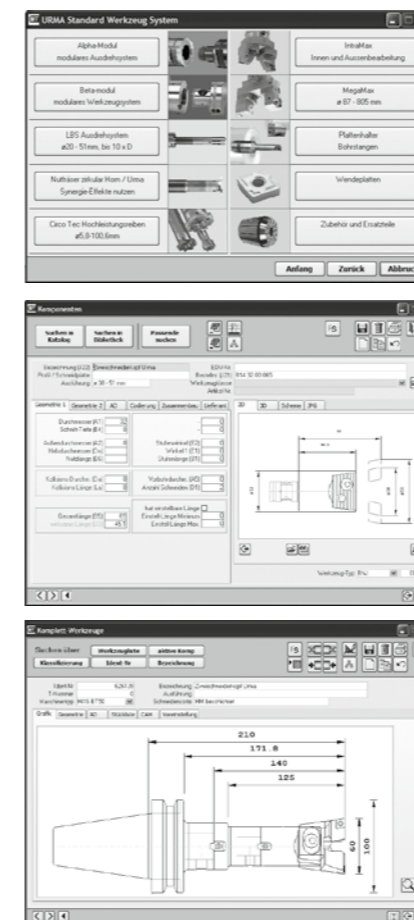

Die Standard Werkzeugverwaltung mit integriertem URMA Katalog liefert Komponenten und zusammengebaute Komplettwerkzeuge auf Knopfdruck.

WinTool Software und URMA Kataloge sind in verschiedenen Sprachversionen zum kostenlosen download verfügbar unter: www.wintool.com

Tool Sheet URMA

600035 **Double Cutter URMA** Machine Typ - no attachment -

| | |
|----------------------------------|-------|
| Diameter | 60 |
| Cutting length | 0 |
| Radius | 0 |
| Main Arc | 0 |
| Length | 210 |
| Width | 0 |
| Collision Lgt. (L ₀) | 145.6 |
| Collision Dia. | 100 |
| Cutting Width | 0 |
| Side Angle | 0 |
| Weight | 5.4 |
| Price | 0 |

Recorded: 05.08.2016 Modified: 05.08.2016

| Product Code / Sort | Description / Item No. | Image |
|--|--------------------------------|-------|
| 1 BT10 50A 50 070 ø 50x70 mm Beta-modul | Adaptor URMA BT -A | |
| 1 B12 50 40 050 ø 50/40x50 mm Beta-modul | Reduction URMA | |
| 1 B14 40 00 090 ø 50 - 67 mm | Double Cutter URMA | |
| 2 W16 08 09 CC... 09T3... ø 50 - 67 mm | Double Cutter Insert Holder 90 | |

| Material | α_p | α_e | D | z | V_c | f_z | S | F | P | T (min) |
|--|------------|------------|-----|-----|-------|-------|------|-------|-----|-----------|
| Cold work tool steel low alloyed up to 1000 N/mm ² | 3 | 30 | 60 | 2 | 220 | 0.2 | 1167 | 466.8 | 0 | 0 |

The standard tool management system with integrated URMA catalogue delivers tool components and assembled tools.

The latest WinTool software and catalog versions are available in various languages and downloadable for free from: www.wintool.com



URMA AG WERKZEUGFABRIK

Obermatt 3
CH-5102 Rapperswil
Switzerland
T +41 62 889 20 20
F +41 62 889 20 28
info@urma.ch
www.urma.ch

Subsidiaries

URMA GmbH
Eisenbahnstraße 37
DE-77815 Bühl
+49 7223 911 170
info@urma-gmbh.de

URMA Trading (Shanghai) Co. Ltd.
Room 511, Hua Nan Mansion
1988 Dongfang Road
Pudong New District
CN-200125 Shanghai
+86 (21) 6109 6216
info@urmachina.com

Iraupen URMA
Poligono Belartza
ES-20018 Donostia-San Sebastian
Spain
+34 943 667 036
info@iraupen.es

License Manufacturer

Command Tooling Systems, LLC
13931 Sunfish Lake Blvd.
Ramsey MN, 55303 USA
+1 800 328 2197
support@commandtool.com

Paul Horn GmbH
Unter dem Holz 33-35
DE-72072 Tübingen
+49 (0) 7071 7004 0
info@phorn.de

Sumitomo Electric Ind., Ltd.
1-1-1, Koyakita,
Itami-shi, Hyogo 664-0016
Japan
+81 72 772 4535
info@sumitomotool.com